

# QUATTROCONE



IPS

IMPLANT SYSTEMS

## QUATTROCONE Catalog 2021/22

Thank you for your trust



## System description

The QUATTROCONE implant	4
The QUATTROCONE30 implant	6
QUATTROCONE30 - QuattroFix	8
Implant diameters and lengths	10
Implant connections	11
Continuity of emergence profile	11
Drills	12
Conventional treatment planning	15
Drill stops and combination tables	16
Computer-aided treatment planning with MedentiGuide	18
Surgical tray	20
Surgical tray layout diagram	22
Surgery washing tray	24
Surgery washing tray layout diagram	26
The new placement instrument	31
Torque ratchet surgical	31
The drilling protocol	34
QUATTROCONE	35
Implant bed preparation	35
Implant insertion	36
Option 1: Transgingival healing	37
Option 2: Submerged healing	38
Option 3: Immediate restoration with a provisional	39
QUATTROCONE30	40
Implant bed preparation	40
Implant insertion	41
Inserting the abutment	42
Clinical examples of QuattroFix	44
Science	46

## Product catalog

Surgery	50
Prosthetics	75
Prosthetic tools	95
Accessories	98



# The QUATTROCONE implant

Primary stability

Bone preserving

High precision conical connection between implant and abutment

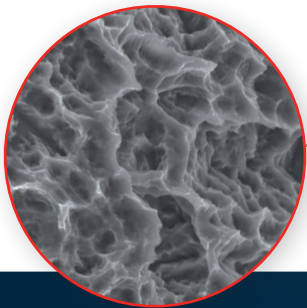

## **SURFACE**

The highly pure, sand-blasted and acid-etched surface extends the entire length of the implant to the machined implant shoulder. It possesses macro-micro roughness that is ideally dimensioned for the deposition of bone-forming cells and thus enhances the ideal and above all reliable long-term osseointegration of the implant. It ensures well above average crestal bone formation in conjunction with the coronal microthread and the conical interface, throughout the implant shoulder to the interface.

## **FORM**

The body of the QUATTROCONE implant is root shaped and, in combination with a high-profile thread and three cutting edges, ensures high primary stability, even in challenging situations. Perfect for immediate implant placement and immediate loading.

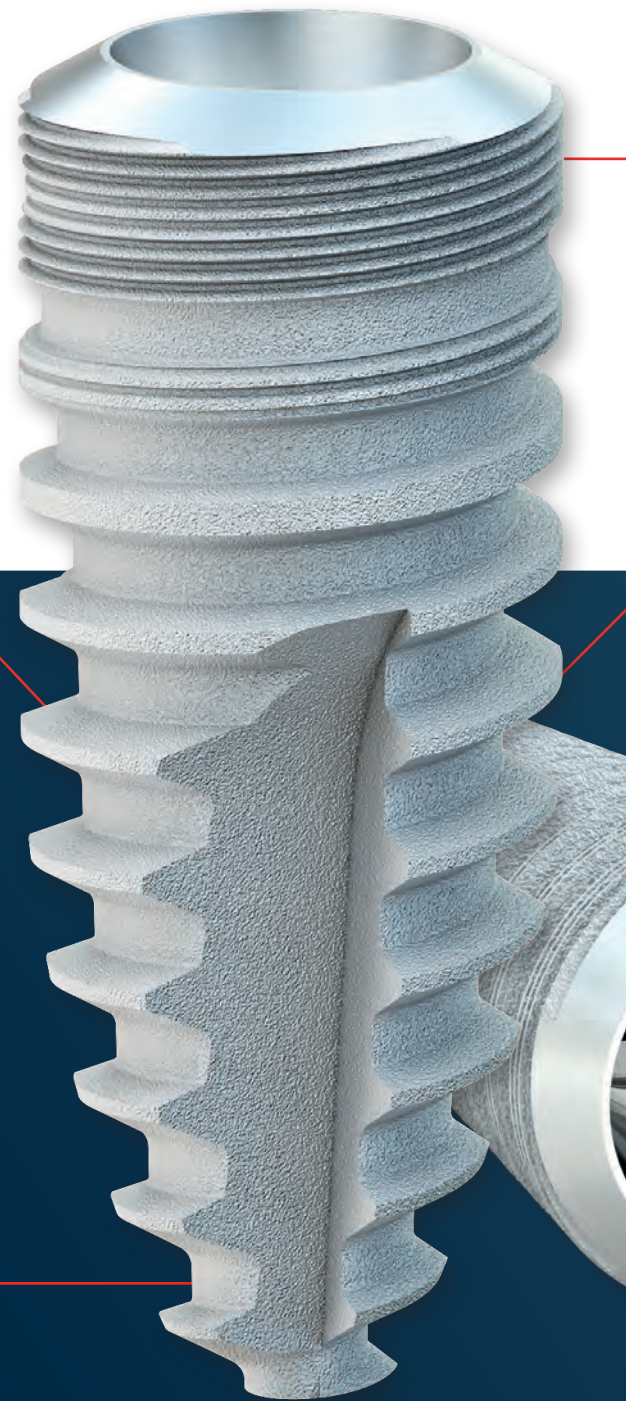



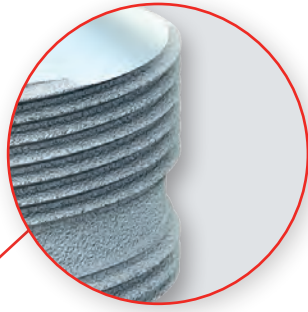

## CRESTAL MICROTHREAD

The crestal microthread may promote the permanent apposition of bone cells and their retention in the crestal region. With subcrestal insertion, in combination with the high precision conical inner connection, it produces apposition of the bone past the shoulder to the interface.

## MACROTHREAD

Very high primary stability in all bone conditions with newly developed high-profile thread. It is self-tapping and gentle on the bone while still exhibiting extremely high primary stability. The thread pitch of 1 mm per rotation reduces insertion times.

## IMPLANT CONNECTION

The high precision friction-locked and keyed interface achieves the best possible levels of stability between the abutment and the implant.

1. One identical conical connection between the implant and abutment for all QUATTROCONE implant diameters.
2. The conical connection between the implant and the abutment is virtually free from micromovements. As a result of this no mechanical irritations arise and the retention of the peri-implant bone is positively influenced.
3. The connection is almost bacteria and liquid proof and can reduce the risk of infection. It supports the development of healthy tissue that is not irritable and prevents bone depletion.
4. Integrated system-linked platform switching shifts the transition between the implant and the abutment from the implant shoulder to a central position. This keeps bacterial stimuli away from the peri-implant tissue in conjunction with the tight conical connection and creates a broad horizontal basis for the stable apposition of hard and soft tissue.
5. In conjunction with a subcrestal implant position and the coronal microthread section, the implant abutment connection meets all system requirements for permanent red-white esthetics.

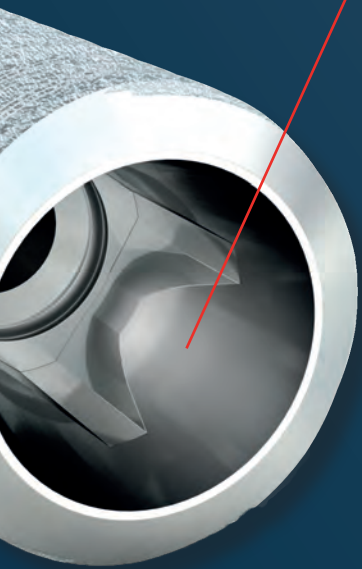

# The QUATTROCONE30 implant

international  
patent  
pending

Specially developed and patented for the QuattroFix\* treatment concept and all indications with angled implant insertion.

## SURFACE

The high purity, sand-blasted and acid-etched surface extends the entire length of the implant to the (machined) implant shoulder. It possesses macro-micro roughness that is ideally dimensioned for the deposition of bone-forming cells and thus enhances the ideal and above all reliable long-term osseointegration of the QUATTROCONE30 implant. It ensures well above average crestal bone formation in conjunction with the coronal microthread and the conical interface, throughout the implant shoulder to the interface.

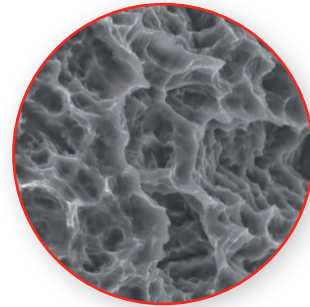

## FORM

The body of the QUATTROCONE30 implant extends in a root shaped pattern and, in combination with a high-profile thread and three cutting edges, ensures high primary stability, even in challenging situations. Perfect for immediate implant placement and immediate loading.

## MACROTHREAD

The macrothread geometry has been developed for a 30° inclined position. 30° thread flanks ensure optimal transfer of forces in the bone. No implant tilting.

Thread pitch reduced to 0.60 mm per rotation enables precise vertical positioning and rotational alignment of the implant body in the bone and guarantees very high primary stability.

### **IMPLANT SHOULDER 30°**

Shoulder angled at 30°. For final positioning flush with the bone when positioned at a 30° angle with QuattroFix\*.

### **MICROSTRUCTURE**

Crestal micro-groove structure. For long-term bone preservation with the QuattroFix\*.

### **IMPLANT CONNECTION**

Specially developed, very deep primary conical implant connection distributes the forces applied at a 30° angle deep into the implant and ensures high mechanical stability reserves. Malpositioning of the abutment is impossible as there is only one single possible rotational position.

\* QuattroFix is a special treatment concept for fixed, full-arch restoration for edentulous patients with an atrophic alveolar ridge on two straight and two 30-degree-angled implants.



# QUATTROCONE30 - QuattroFix

QuattroFix is a special concept for fixed, full-arch restoration for edentulous patients with an atrophic alveolar ridge on two straight and two 30 degree-angled implants.

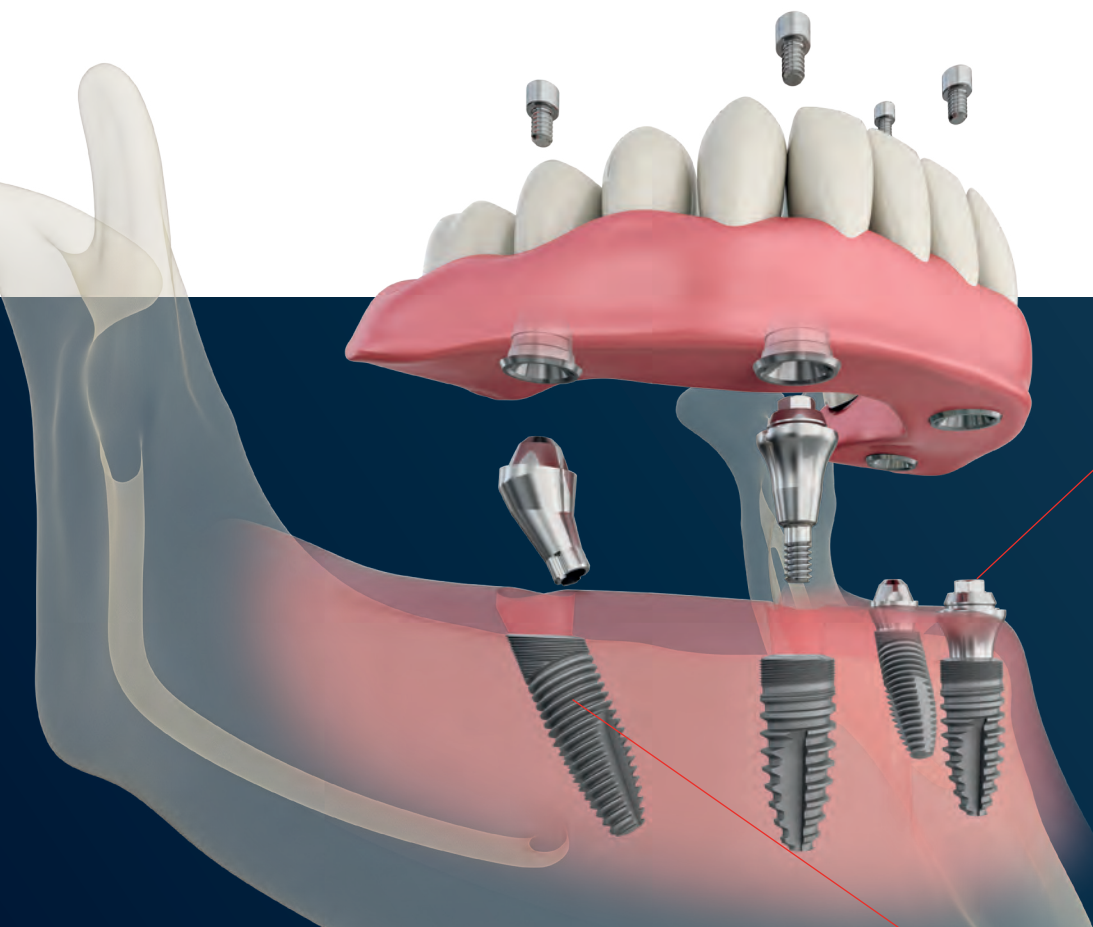

## ADVANTAGES OF THE QUATTROFIX TREATMENT CONCEPT



### IMMEDIATE TREATMENT

Immediate esthetic and functional solution



### PERMANENT

Treatment with fixed prosthetic solution.



### HIGH PRIMARY STABILITY

High stability achieved by implants designed specifically for 30 degree-angled positioning.



### TREATMENT TIME

Shorter treatment time



### VERSATILITY

Even in low bone volumes, bone augmentation is rarely required.



## MULTI-UNIT ABUTMENTS

The final restoration is screwed onto the implants with the multi-unit abutments. The straight and 30 degree-angled multi-unit abutments allow optimal distribution of force on the bone.

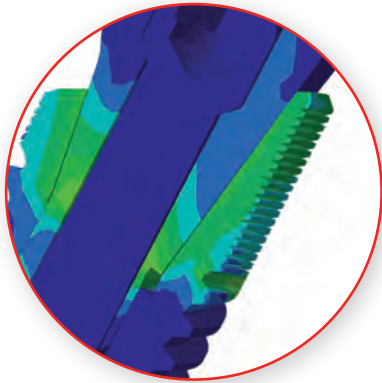

## QUATTROCONE30 IMPLANT CONNECTION

The implant connection has been developed specifically for angled insertion. Its very deep conical force-locking and interlocking tapered connection widely distributes the applied forces into the implant. The finite element analyses performed with the QUATTROCONE30 show a very uniform and completely uncritical distribution of the von Mises stresses in the implant shoulder region with a loading of 250 N. The special QUATTROCONE30 implant connection efficiently prevents the stress peaks that would otherwise arise under these conditions. This in turn protects the surrounding bone in this particularly sensitive region.

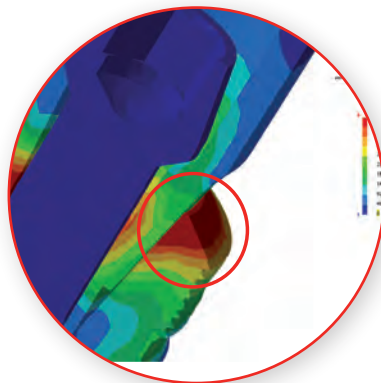

## CONVENTIONAL IMPLANT CONNECTION

Conventional implant interface connections have partially high stress peaks in the implant shoulder region when an implant is inserted at an angle of 30°. These can have a detrimental effect on the surrounding bone.

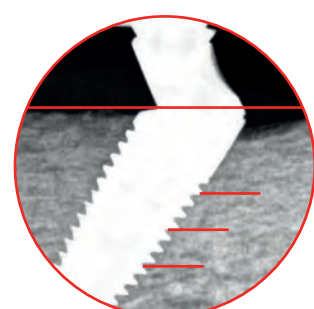
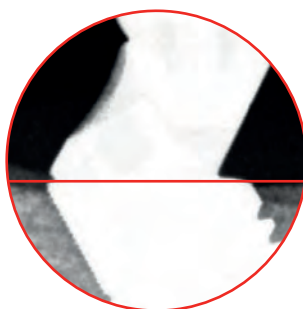
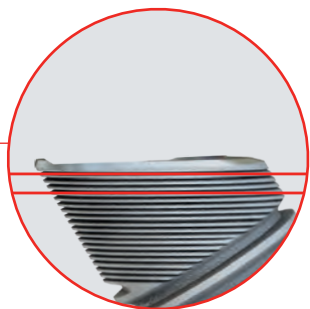

## QUATTROCONE30 THREAD DESIGN

The uniquely shaped and patented design of the QUATTROCONE30 implants has been specially developed for inclined implant insertion and thus bone preservation. Cases in which QuattroFix\* is indicated have their own special requirements. This is the first solution to proficiently address these requirements both scientifically and technically.

As the flanks of the macrothread are angled at 30°, inserted at an angle, these implants behave like a conventional implant when an axial load is introduced – ideal! Both tipping movements of the implant and excessive stress in the critical crestal bone region are eliminated. This ensures reliable implant placement with lasting stability.

\* QuattroFix is a special treatment concept for fixed, full-arch restoration for edentulous patients with an atrophic alveolar ridge on two straight and two 30 degree-angled implants.

# Implant diameters and lengths



D 3.5

D 3.8

D 4.3

D 5.0

Clear color coding of the implant diameters

The visible indication of the implant diameter, framed by the color coding, makes it easier to visually differentiate the respective implant diameters. The drill parts for the implant bed preparation are also highlighted with these colors.

		LENGTH DIAMETER	L 7.0	L 9.0	L 11.0	L 13.0	L 15.0
QUATTROCONO	RI*	D 3.5		 3-01-02	 3-01-03	 3-01-04	 3-01-05
		D 3.8	 3-01-16	 3-01-17	 3-01-18	 3-01-19	 3-01-20
		D 4.3	 3-01-06	 3-01-07	 3-01-08	 3-01-09	 3-01-10
		D 5.0	 3-01-11	 3-01-12	 3-01-13	 3-01-14	 3-01-15
QUATTROCONO30	AI*	D 4.3		 4-01-01	 4-01-02	 4-01-03	 4-01-04
		D 5.0		 4-01-06	 4-01-07	 4-01-08	 4-01-09

\* Implant connection RI  
(Regular interface)

Implant connection AI  
(Angulated interface)



# Implant connections

## RI

QUATTROCONE implant  
RI D 3.5 mm – 5.0 mm

There is only one conical implant connection size between the implant and the abutment in the case of implants with a diameter of 3.5 mm - 5.0 mm, which is marked with RI (Regular Interface). This means that all the Implant pick-ups, gingiva formers and abutments fit into each of these implants. This markedly reduces the number of components required and thus achieves maximum transparency and efficiency.





## AI

QUATTROCONE30 implant  
AI D 4.3 mm – 5.0 mm

Please note that it is essential that the QUATTROCONE30 implant with a diameter of 4.3 mm - 5.0 mm is only used with parts labeled with the implant connection AI (Angulated Interface).

## Continuity of emergence profile

The shape (emergence profile) of the gingiva former and the temporary abutment exactly follows the shape of the prosthetic abutment. Optional individual implant pick-ups are available to better transfer the selected emergence profile to the model. These are also based exactly on the emergence profile of the gingiva former and abutment.

Implants	QUATTROCONE RI D 3.5 - 5.0			
	Gingiva former			Temporary
Gingiva former /Temporary restoration	 Ø 4.5 GH 1-6	 Ø 5.5 GH 1-6	 Ø 6.5 GH 1-6	 Ø 5.5 GH 1-6
Implant pick-up				
Emergence profile for Implant pick-up	 Ø 4.5 GH 1-2	 Ø 5.5 GH 1-2	 Ø 6.5 GH 1-2	 Ø 5.5 GH 1-2
	 Ø 4.5 GH 3-6	 Ø 5.5 GH 3-6	 Ø 6.5 GH 3-6	 Ø 5.5 GH 3-6
Abutment	 Ø 4.5 GH 1.5-5	 Ø 5.5 GH 1.5-5	 Ø 6.5 GH 1.5-5	 Ø 5.5 GH 1.5-5

# Drill

The three cutting edges of the step drill are designed to match the outer geometry of the implant. QUATTROCONE implants can be positioned with two drilling steps. If diameters are larger, incremental drilling is recommended. Different step drills for D1/D2 bones and D3/D4 bones.

Bright depth markings ensure optimum visibility.

Long service lives due to black surface coating.

Clear color coding and only 4 drills in total greatly simplify the protocol.

The QUATTROCONE standard and cortical drills are generally step drills, whose steps match the apical shape of the implant, depending on the respective implant diameter.

## MARKER DRILL

The marker drill is used to punch mark the bone before the first deep drilling step. Two variants are available. The first is the round drill (0-14-75) and the second is the needle drill (0-14-77). This can be used to guide the drilling process for instance, if the bone is tapered or for drilling in extraction sockets. The needle drill also features depth markings of 6 mm to 10 mm for depth measurement.

## ROUND DRILL



## NEEDLE DRILL

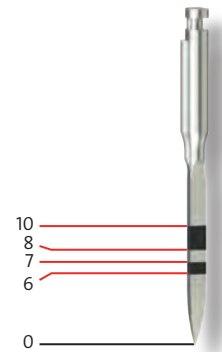

## DRILL TYPES

Depending on the implant diameter and bone quality, up to five different drill types are available for the gentle preparation of the bony implant bed. The color coding makes choosing the right drill extremely easy.



### THE PILOT DRILL

is marked with a gray ring and is used as the first depth drill and axis alignment for any implant diameter.



### THE STANDARD DRILL

is used for the final depth drilling of the corresponding implant diameter for D3/D4 bone quality. It is also used for incremental drilling for large implant diameters. Its implant diameter can be identified by its color ring.

If using the standard drill for the final deep drilling, the following always applies: Implant diameter minus 0.3 mm (e.g. D 3.5 mm = 3.2 mm final drill hole)



### THE CORTICAL DRILL

is used for the final depth drill for D1/D2 bone quality in addition to the standard drill. Alongside the color coding for the implant diameter it also has a red ring

If using the cortical drill for the final deep drilling, the following always applies: Implant diameter minus 0.2 mm (e.g. for implant D 3.5 mm = 3.3 mm final drill hole).

Especially suitable for D1/D2 bone quality in the lower jaw. Here, if necessary, at full depth.

A detailed drilling protocol is available on page 34

### THREE DRILL LENGTHS

There are three drill lengths available for each implant diameter which can be differentiated based on the narrow, silver marking rings. The choice of drill length is only determined by the space available in the mouth. The depth marking on the cutting surfaces is identical for all three drill lengths.

The drill lengths must, however, be taken into consideration when using and selecting the appropriate drill stops. Detailed information is available under „Drill stops and combination tables“ on page 16.

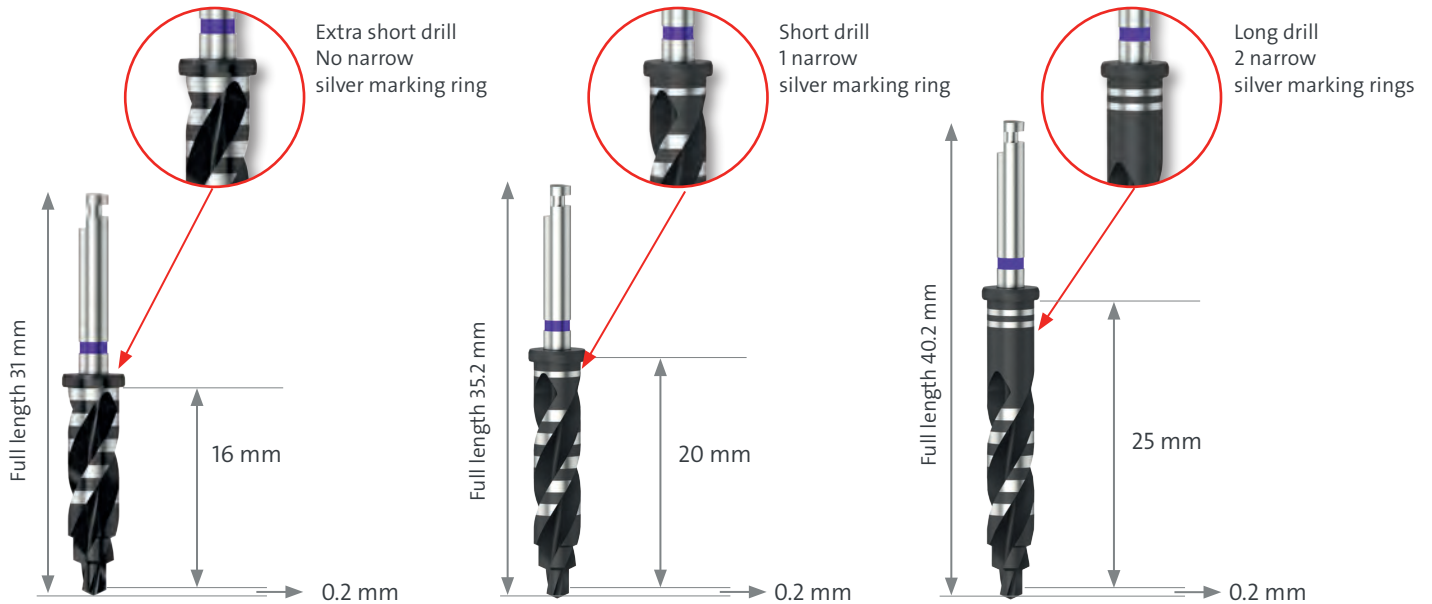

The MedentiGuide System supports all drill lengths.\* In the planning phase it is important to ensure that the correct drill length is selected.

### DEPTH MARKING

The depth markings on the cutting edges of the drill are graduated according to the available QUATTROCONE and QUATTROCONE30 implant lengths.

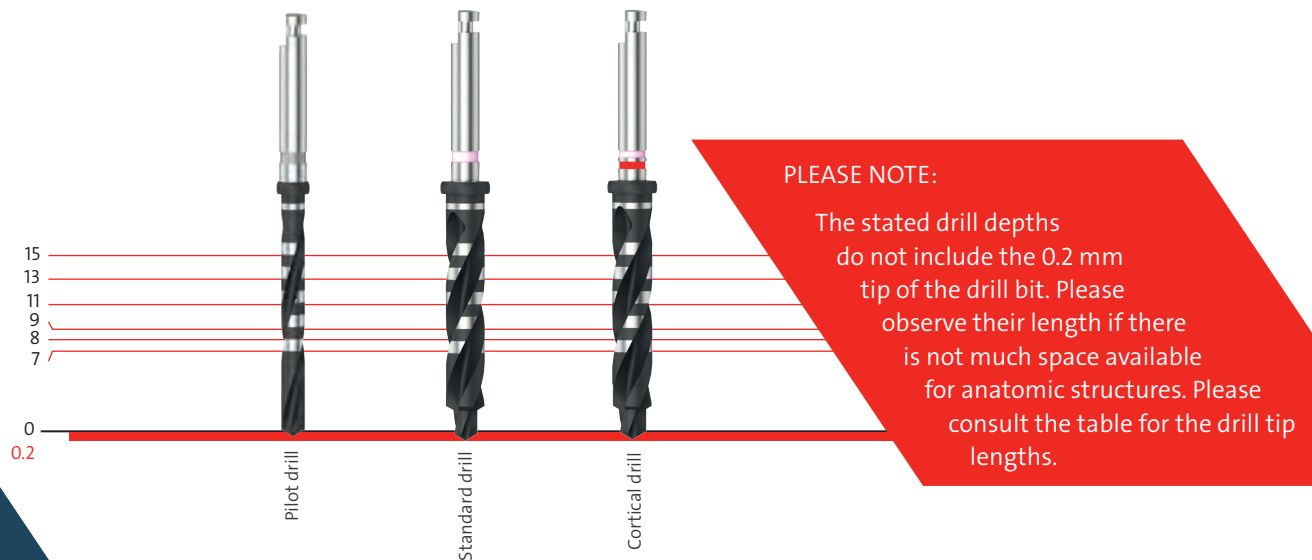

The QUATTROCONE standard and cortical drills are generally step drills whose steps match the apical shape of the implant, depending on the respective implant diameter.

\* depending on the planning software used.



**DEPTH MARKING**

**QUATTROCONE**

**QUATTROCONE30**

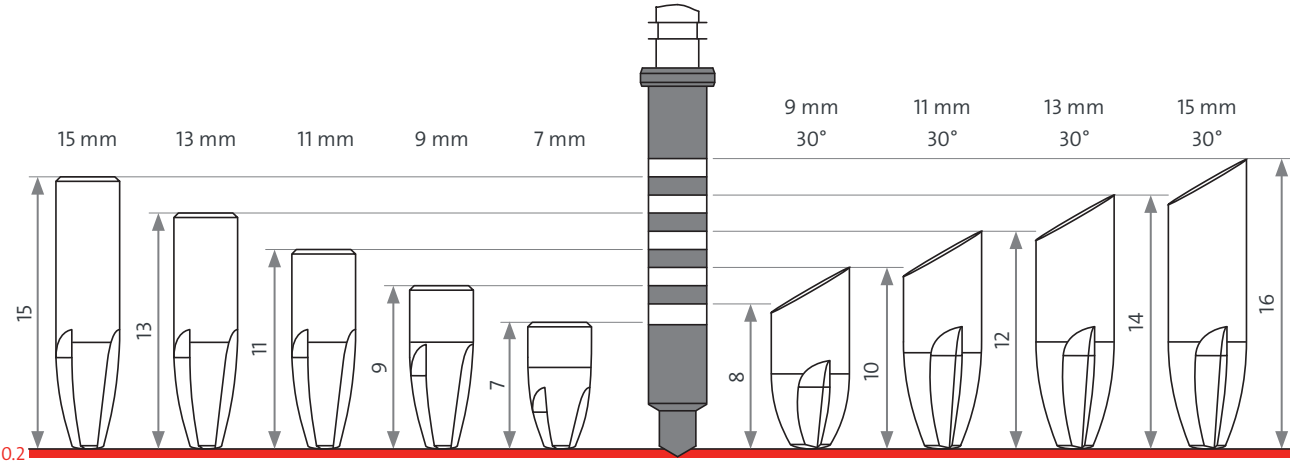

**QUATTROCONE30**

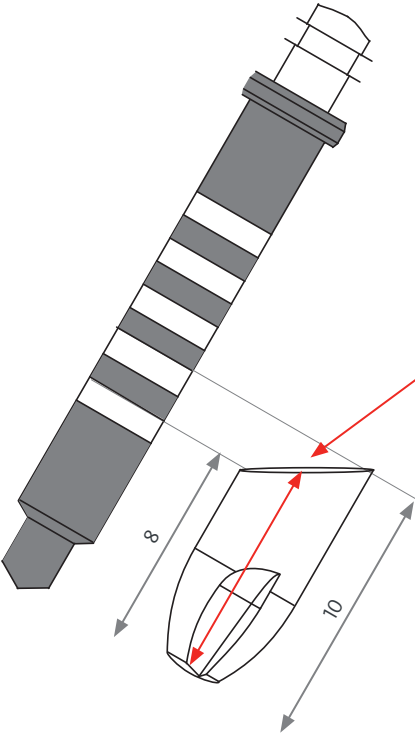

Implant length L 9.0

**QUATTROCONE30 LENGTH SPECIFICATIONS**

The implant length is the distance between the implant tip and shoulder in the central axis region.

# Conventional treatment planning

Treatment planning must take generally applicable guidelines for implant prosthetics into account, along with surgical perspectives such as general patient history, contraindications, intraoral findings and risk factors.

Once the findings have been evaluated, treatment can be planned based on the following considerations:

- Preprosthetic planning
- Surgical planning

The indications and contraindications for dental surgery

and implantology must be taken into account.

In the preprosthetic planning, the best possible placement of the implants should be planned in consultation with the prosthodontist with esthetics and function in mind.

In the surgical planning it is important to carefully assess if there is sufficient bone available to ensure primary stability of the implants.

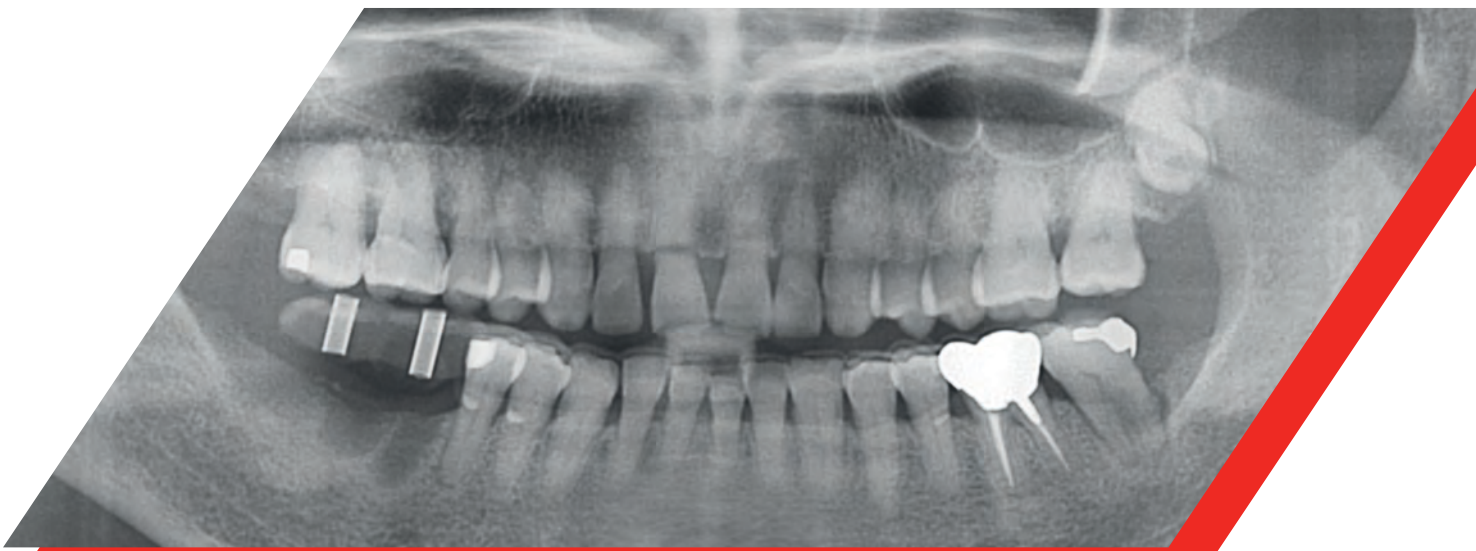

## SURGICAL PLANNING

In the preoperative planning it is important to carefully assess whether the jaw bone is sufficiently wide and high to hold implants. Vestibular and oral lamella should be at least 1.5 mm wide after implant insertion. Determine the position and orientation of important anatomical structures such as the mental foramen or sinus cavity radiographically. If augmentation is required, these regions must demonstrate complete and mechanically stable regeneration before preparation. Implant lengths and diameters are selected by placing the X-ray template on the OPG (note the magnification scale). A subcrestal positioning of the implant must be taken into account in the X-ray analysis.

## PREPROSTHETIC PLANNING

Preprosthetic planning and thus the best possible, tooth-analog positioning of the implants is the most important prerequisite for ensuring the implantation is a sound foundation for an esthetic and functional prosthesis.

# Drill stops and combination tables

















The QUATTROCONE drill stop ensures precise control of the drilling depth during implant bed preparation for placing QUATTROCONE implants. The advantage of this drill stop is that it can be used for both simple and more complex cases where the position of the mandibular nerve or sinus floor is relevant. The drill stops are supplied nonsterile and should be sterilised prior to use. The drill stops may be used only with the QUATTROCONE drills. The drill stops are available for all implant diameters and lengths.



















## PLEASE NOTE:

QUATTROCONE drill stops are not indicated for:

















1. Extraction sockets, in which the bone cavity is much wider than the required support diameter for the drill stop.
2. Use as guide sleeves in drill templates.

Extra-short drill (16 mm)						
	Implant diameter/drill type	Implant length				
		L 7.0	L 9.0	L 11.0	L 13.0	L 15.0
QUATTROCONE						
	<b>All implant diameters</b> Pilot drill Ø2.0mm		6 (4-14-16)	4 (4-14-14)	2 (4-14-12)	
	<b>D 3.5</b> Standard/Cortical		20 (4-14-30)	18 (4-14-28)	16 (4-14-26)	
	<b>D 3.8</b> Standard/Cortical		59 (4-14-77)	58 (4-14-76)	57 (4-14-75)	
	<b>D 4.3</b> Standard/Cortical		34 (4-14-44)	32 (4-14-42)	30 (4-14-40)	
	<b>D 5.0</b> Standard/Cortical		48 (4-14-62)	46 (4-14-60)	44 (4-14-58)	
QUATTROCONE30						
	<b>All implant diameters</b> Pilot drill Ø2.0mm			3 (4-14-13)	1 (4-14-11)	
	<b>D 4.3</b> Standard/Cortical			31 (4-14-41)	29 (4-14-39)	
	<b>D 5.0</b> Standard/Cortical			45 (4-14-59)	43 (4-14-57)	
			Drill stop number			

## Short drill (20 mm)

Implant diameter/drill type		Implant length					
		L 7.0	L 9.0	L 11.0	L 13.0	L 15.0	
QUATTROCONE							
	<b>All implant diameters</b> Pilot drill Ø2.0mm		10 (4-14-20)	8 (4-14-18)	6 (4-14-16)	4 (4-14-14)	2 (4-14-12)
	<b>D 3.5</b> Standard/Cortical		24 (4-14-34)	22 (4-14-32)	20 (4-14-30)	18 (4-14-28)	16 (4-14-26)
	<b>D 3.8</b> Standard/Cortical		63 (4-14-81)	61 (4-14-79)	59 (4-14-77)	58 (4-14-76)	57 (4-14-75)
	<b>D 4.3</b> Standard/Cortical		38 (4-14-48)	36 (4-14-46)	34 (4-14-44)	32 (4-14-42)	30 (4-14-40)
	<b>D 5.0</b> Standard/Cortical		52 (4-14-66)	50 (4-14-64)	48 (4-14-62)	46 (4-14-60)	44 (4-14-58)
QUATTROCONE30							
	<b>All implant diameters</b> Pilot drill Ø2.0mm			7 (4-14-14)	5 (4-14-15)	3 (4-14-13)	1 (4-14-11)
	<b>D 4.3</b> Standard/Cortical			35 (4-14-45)	33 (4-14-43)	31 (4-14-41)	29 (4-14-39)
	<b>D 5.0</b> Standard/Cortical			49 (4-14-63)	47 (4-14-61)	45 (4-14-59)	43 (4-14-57)
Drill stop number							

## Long drill (25 mm)

Implant diameter/drill type		Implant length					
		L 7.0	L 9.0	L 11.0	L 13.0	L 15.0	
QUATTROCONE							
	<b>All implant diameters</b> Pilot drill Ø2.0mm		14 (4-14-24)	13 (4-14-23)	11 (4-14-21)	9 (4-14-19)	7 (4-14-17)
	<b>D 3.5</b> Standard/Cortical		28 (4-14-38)	27 (4-14-37)	25 (4-14-35)	23 (4-14-33)	21 (4-14-31)
	<b>D 3.8</b> Standard/Cortical		66 (4-14-84)	65 (4-14-83)	64 (4-14-82)	62 (4-14-80)	60 (4-14-78)
	<b>D 4.3</b> Standard/Cortical		42 (4-14-52)	41 (4-14-51)	39 (4-14-49)	37 (4-14-47)	35 (4-14-45)
	<b>D 5.0</b> Standard/Cortical		56 (4-14-70)	55 (4-14-69)	53 (4-14-67)	51 (4-14-65)	49 (4-14-63)
QUATTROCONE30							
	<b>All implant diameters</b> Pilot drill Ø2.0mm			12 (4-14-22)	10 (4-14-20)	8 (4-14-18)	6 (4-14-16)
	<b>D 4.3</b> Standard/Cortical			40 (4-14-50)	38 (4-14-48)	36 (4-14-46)	34 (4-14-44)
	<b>D 5.0</b> Standard/Cortical			54 (4-14-68)	52 (4-14-66)	50 (4-14-64)	48 (4-14-62)
Drill stop number							

# Computer-aided treatment planning with MedentiGuide

MedentiGuide

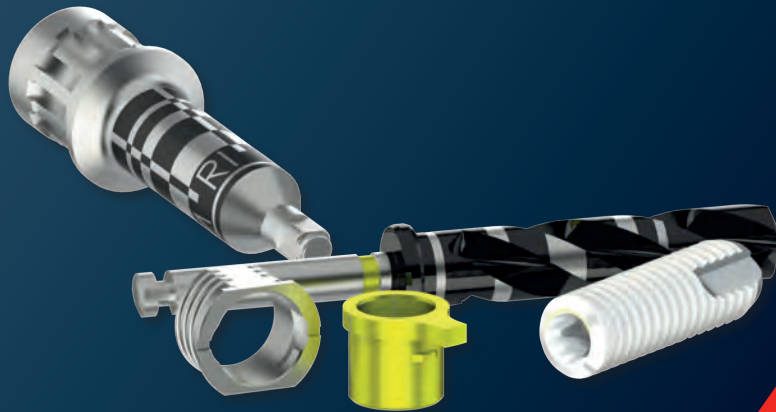

MedentiGuide drill sleeves support the surgeon in preparing the implant bed for Medentika® implants. Their use must be planned with a specially designed 3D planning system and surgical drilling template. You can plan the surgery with standard planning programs.

Treatment planning based on three dimensional imaging procedures (CT, DVT) enables high precision treatment planning with predictable outcomes.

The advantages over conventional planning include:

- Precision three-dimensional planning and implantation, taking into account the desired restoration
- Automatic collision control that displays if the distances to the implants or nerves are too short
- Information on peri-implant bone quality so that conclusions can be drawn on the expected primary stability

An individual drilling template can be produced on the basis of the digital planning data. This ensures the exact and precise transfer of the planning outcome to the patient's mouth.



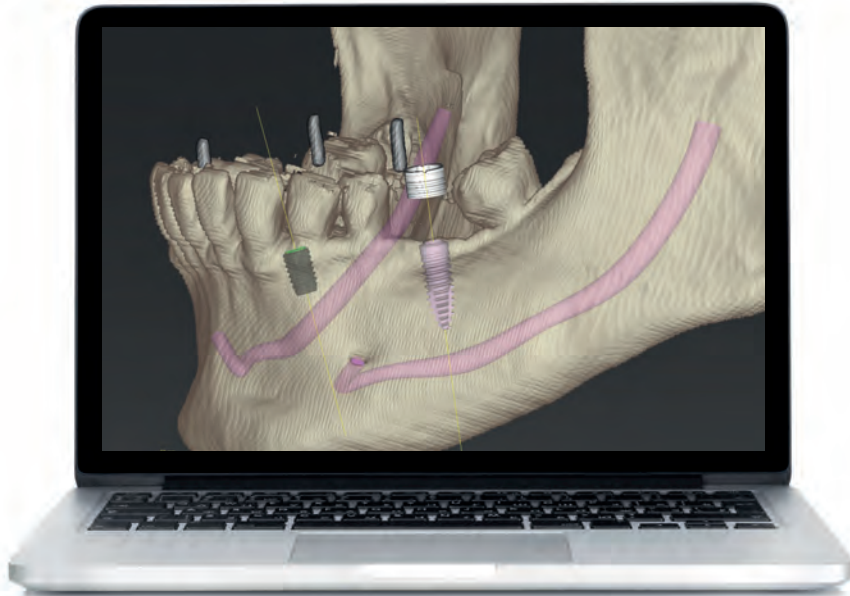

These software manufacturers\* currently support the MedentiGuide System



Note:

Medentika® GmbH accepts no liability for the correct planning, implementation and production of the drilling template. Sufficient knowledge of the 3D planning system being used and the Medentika® implant system is essential. It is imperative that the user is very confident in the use of 3D planning systems before using the MedentiGuide drill sleeves. Furthermore, sufficient expertise in preoperative implant planning and dental implantology is required.

\* to some extent this depends on the availability of the updates of the specific manufacturer.

# Surgical tray

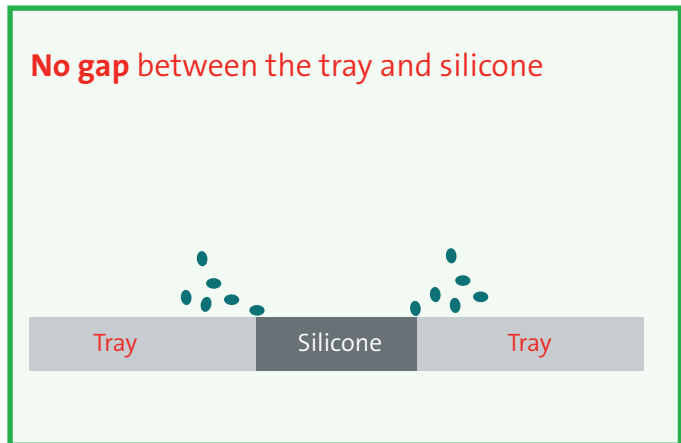

## The benefits

- 1 Superior hygiene capability with intelligently designed silicone holders
- 2 Smooth, even surfaces accelerate and facilitate cleaning
- 3 Space for another drill set
- 4 9 additional slots
- 5 Removable metal dish for small parts



# Surgical tray layout diagram

The surgical tray is available with four layout options:

- As tray without contents
- Prefilled with the most important extra short design instruments
- Prefilled with the most important short design instruments
- Prefilled with the most important long design instruments

The exact layout of the surgical washing tray is shown in the item list of the corresponding variant.

There is space for two drill sets and the associated placement instruments and free slots for additional instruments.





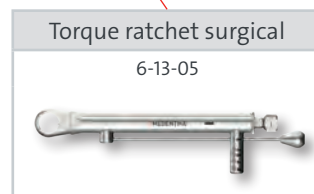
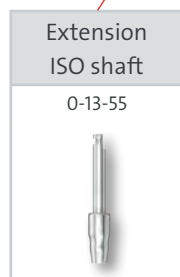





Removable stainless steel dish for small parts







Located in the floor of the surgery tray







Marker		Pilot	Bone quality	D3.5	D3.8	D4.3	D5.0
Needle drill 0-14-77	Round drill 0-14-75	e-s: 4-14-85 s: 4-14-01 l: 4-14-06	D3/D4	 e-s: 4-14-86 s: 4-14-02 l: 4-14-07	 e-s: 4-14-92 s: 4-14-71 l: 4-14-73	 e-s: 4-14-88 s: 4-14-04 l: 4-14-09	 e-s: 4-14-90 s: 4-14-53 l: 4-14-55
			D1/D2	 e-s: 4-14-87 s: 4-14-03 l: 4-14-08	 e-s: 4-14-93 s: 4-14-72 l: 4-14-74	 e-s: 4-14-89 s: 4-14-05 l: 4-14-10	 e-s: 4-14-91 s: 4-14-54 l: 4-14-56



e-s = extra-short; s = short; l = long



Placement instrument implant RI	
Contra-angle	Manual and ratchet
extra-short 2-13-32 short 2-13-33 long 2-13-34	extra-short 2-13-35 short 2-13-36 long 2-13-37
	

Placement instrument MedentiGuide RI	
Contra-angle	Manual and ratchet
extra-short 3-32-11 short 3-32-07 long 3-32-08	extra-short 3-32-12 short 3-32-09 long 3-32-10
	

Placement instrument implant AI	
Contra-angle	Manual and ratchet
extra-short 4-13-08 short 4-13-09 long 4-13-10	extra-short 4-13-11 short 4-13-12 long 4-13-13
	

Placement instrument MedentiGuide AI	
Contra-angle	Manual and ratchet
short: 4-32-07 long: 4-32-08	short: 4-32-09 long: 4-32-10
	

Placement instrument Hex 1.26	
Contra-angle	Manual and ratchet
extra-short 0-13-18 short 0-13-04 long 0-13-05	short 0-13-22 long 0-13-23
	

Paralleling aid	
Implant RI	Drill
2-13-31	0-13-74
	

Drill aid QUATTROCONO 30
4-13-07



# Surgery washing tray

## THE EFFICIENT CLEANING METHOD.

The new surgery washing tray has been designed for the surgical instruments to be prepared as easily and efficiently as possible.

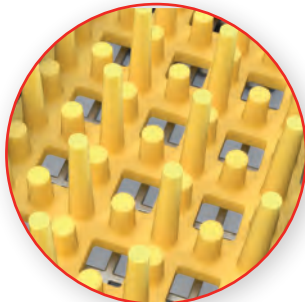
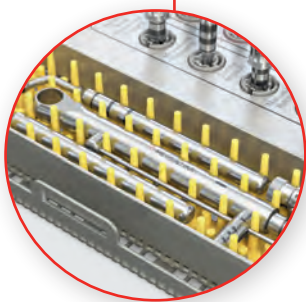
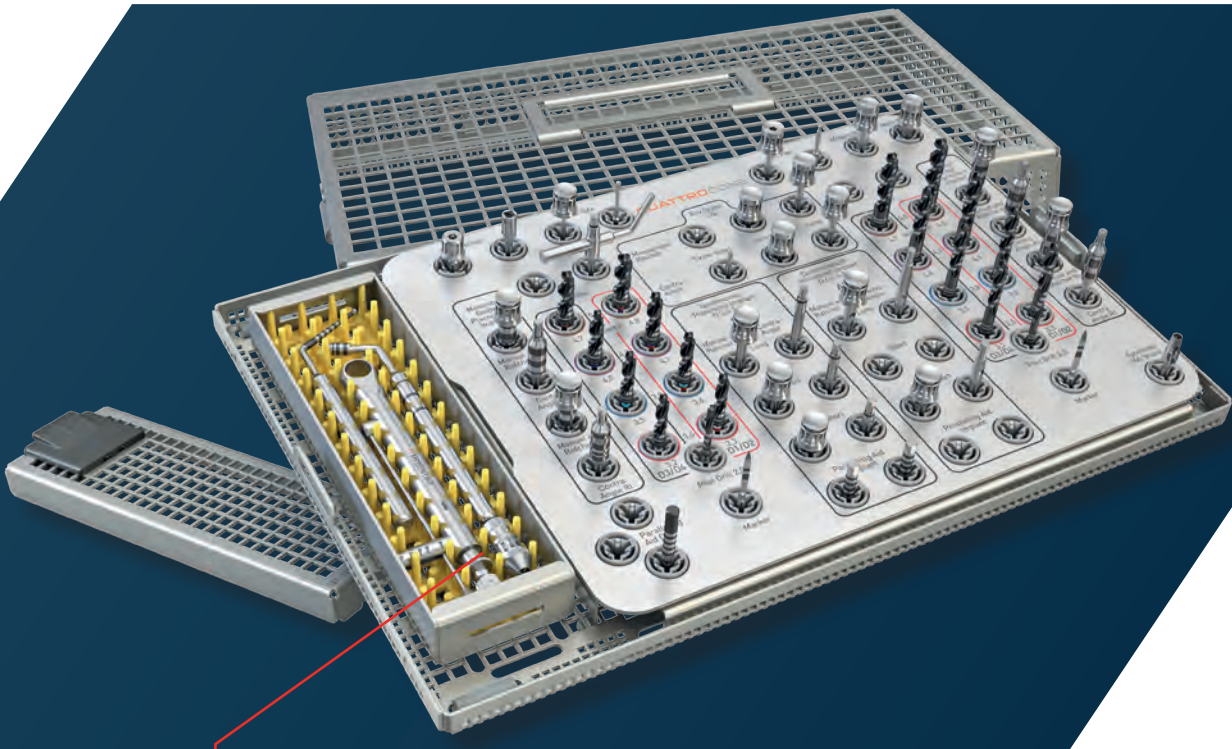

- The separate compartment with a silicone insert is used to store additional instruments, such as the torque ratchet surgical.
- The silicone insert prevents the instruments from touching, thereby preventing contact corrosion and ensuring thorough cleaning.
- The separate lid prevents small instruments from falling out.



If you prefer to use sterile containers, the JN295 from Aesculap®, for example, is a suitable option.



- The surgery washing tray is made of corrosion-free medical stainless steel.
- The height of the tray means that it easily holds even long drills and instruments.
- It can hold two full drill sets and the matching MedentiGuide placement instruments.

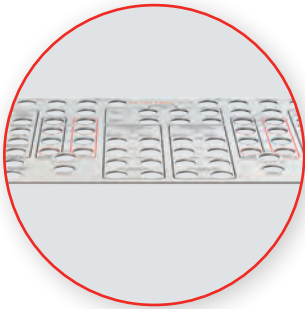

- The aluminum template printed with the layout diagram is used to clearly arrange all instruments.
- The template is removable to optimize the instrument cleaning process.



- The grid structure and the specially designed retaining sleeves with point-by-point instrument holder ensure that all instruments are well rinsed and thereby produces reproducible cleaning results.

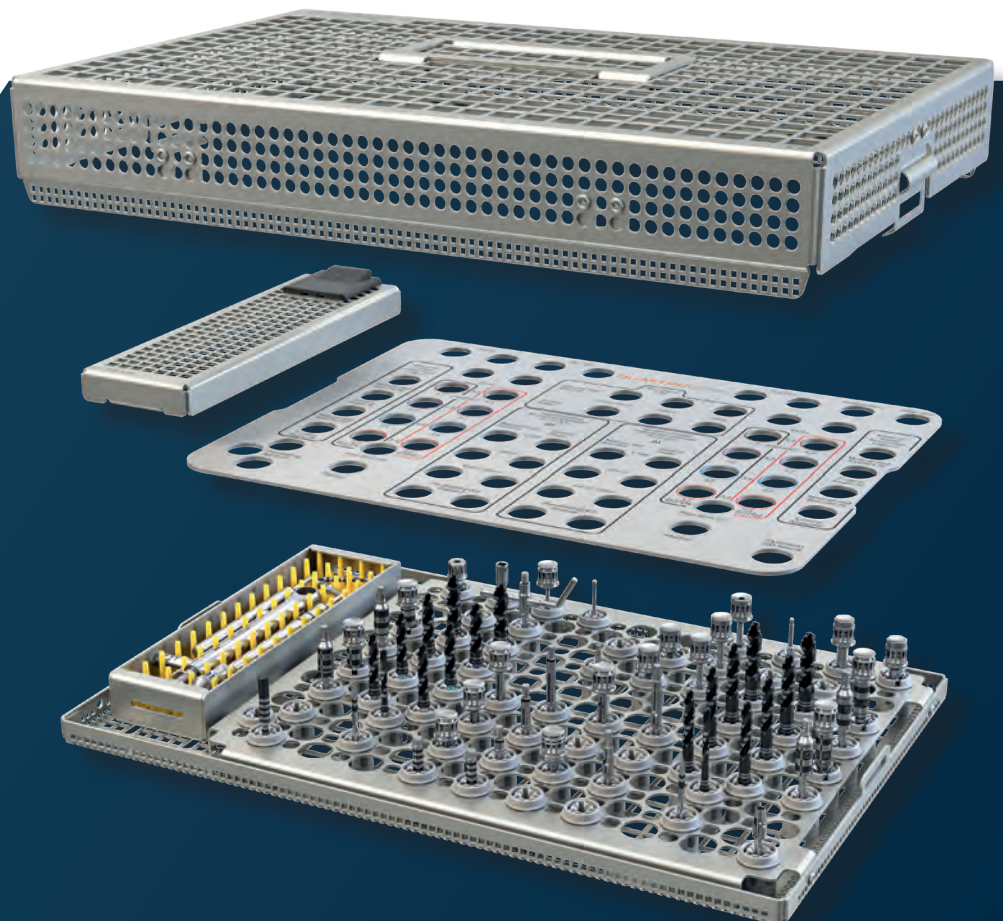

# Surgery washing tray layout diagram

The layout of the surgery washing tray is shown in the item list of the corresponding variant. It can hold two drill lengths and the matching MedentiGuide placement instruments.

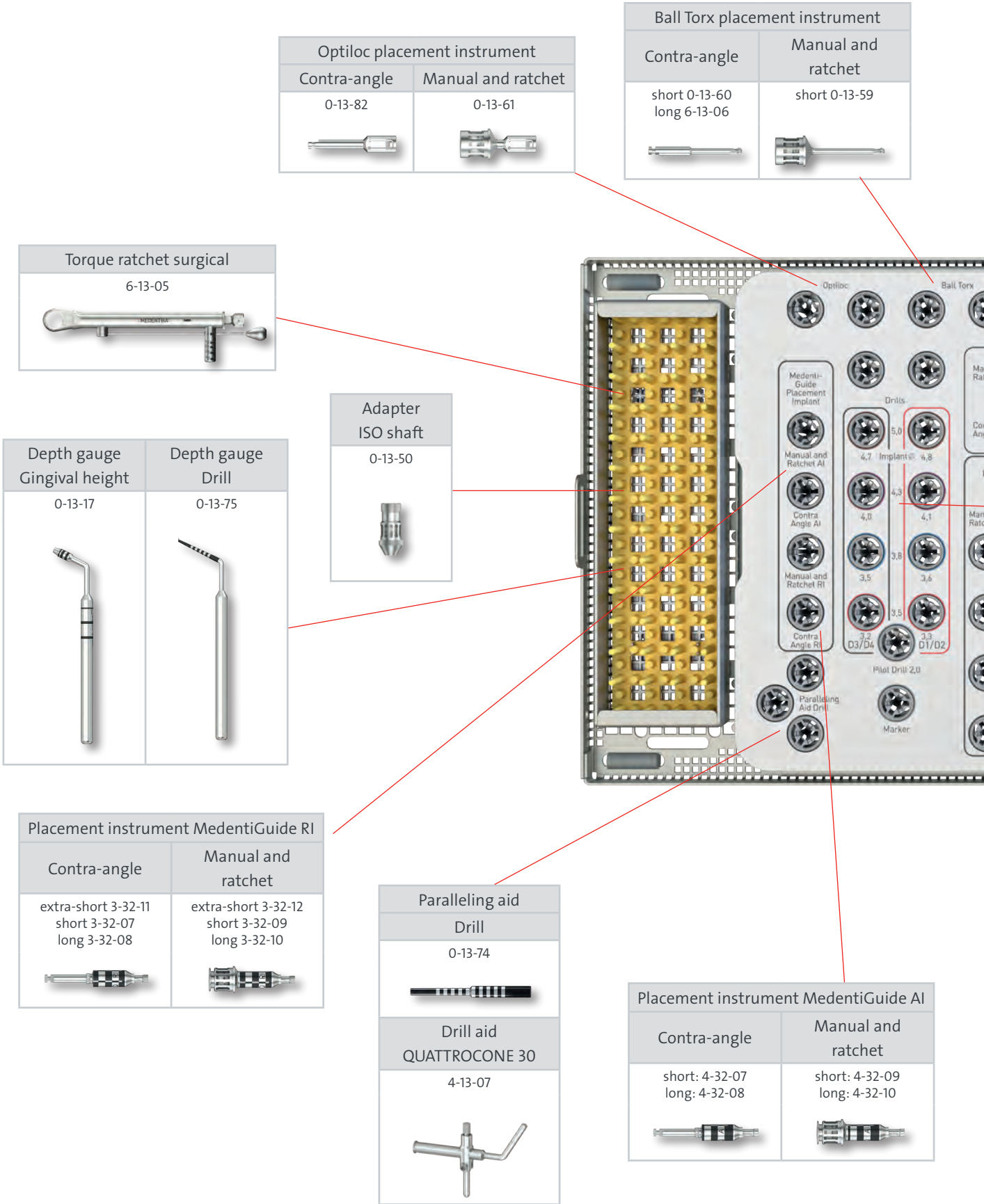



D 3.5

D 3.8

D 4.3

D 5.0

Color coding of the implant diameter

Placement instrument Hex 1.26	
Contra-angle	Manual and ratchet
extra-short 0-13-18 short 0-13-04 long 0-13-05	short 0-13-22 long 0-13-23

Ball Hex placement instrument	
Contra-angle	Manual and ratchet
0-13-39	0-13-38

Placement instrument MedentiBase
0-13-37

Multi-unit placement instrument
0-13-76

Extension ISO shaft
0-13-55

Placement instrument implant AI	
Contra-angle	Manual and ratchet
extra-short 4-13-08 short 4-13-09 long 4-13-10	extra-short 4-13-11 short 4-13-12 long 4-13-13

Placement instrument implant RI		Paralleling aid
Contra-angle	Manual and ratchet	Implant RI
extra-short 2-13-32 short 2-13-33 long 2-13-34	extra-short 2-13-35 short 2-13-36 long 2-13-37	2-13-31

Implant diameter	Standard drill	Cortical drill
D5.0	e-s: 4-14-90 s: 4-14-53 l: 4-14-55	e-s: 4-14-91 s: 4-14-54 l: 4-14-56
D4.3	e-s: 4-14-88 s: 4-14-04 l: 4-14-09	e-s: 4-14-89 s: 4-14-05 l: 4-14-10
D3.8	e-s: 4-14-92 s: 4-14-71 l: 4-14-73	e-s: 4-14-93 s: 4-14-72 l: 4-14-74
D3.5	e-s: 4-14-86 s: 4-14-02 l: 4-14-07	e-s: 4-14-87 s: 4-14-03 l: 4-14-08
Pilot drill	e-s: 4-14-85 s: 4-14-01 l: 4-14-06	
Marker	Needle drill 0-14-77	Round drill 0-14-75

e-s = extra-short; s = short; l = long

# The new implant packaging

The new implant packaging for the QUATTROCONE system has been developed to make handling even easier. The compact implant packaging makes storage more efficient. Important parameters, such as the article number, diameter, length, implant connection and type can be clearly identified.







- The double information label applied over the corner allows flexible implant storage; important product information is visible at a glance.
- Clear, compact information labels with the key data make it easier to distinguish between the implants. The implant diameters are visible at a glance by the color coding on the information labels.



- Implants can be clearly identified through the inspection window



- The perforation on the outer packaging made of environmentally friendly cardboard makes it easy to access the sterile packaging..

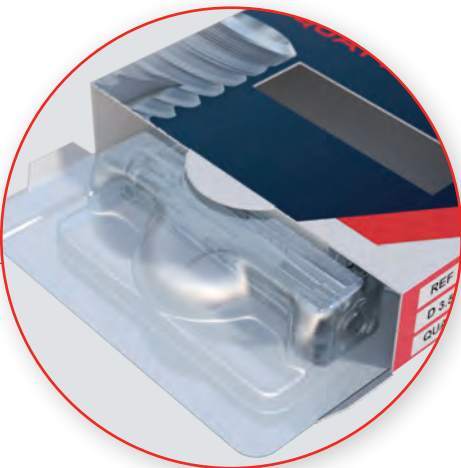

- The implant is supplied in a sterile container, protected by a blister with outer packaging. The blister thereby acts as a sterile barrier.

# The new implant packaging

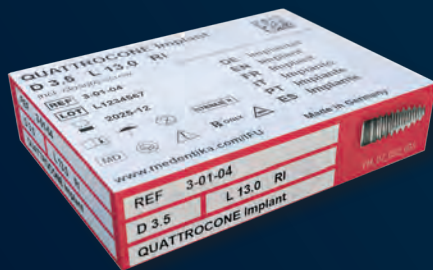





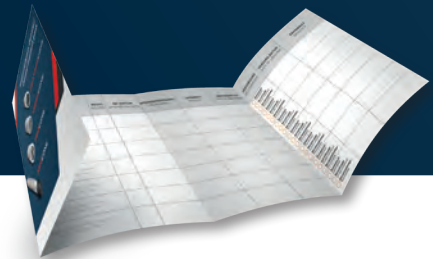









## PATIENT LABEL

There are two peel-off labels on the blister package which can simply be affixed in the implant pass for documentation.



## SYMBOL DESCRIPTION AND IFU

Please refer to the IFU for further information - [www.medentika.com/ifu](http://www.medentika.com/ifu)

	Lot number		Use-by date
	Article number		Do not re-use
	Manufacturer		CE marking with the identification number of the Notified Body
	Date of manufacture		Caution
	See Instructions for Use		Medical device
	Sterilization by radiation		Store dry
	MR Conditional		Do not use if the packaging is damaged
	US Federal law restricts this device to sale by or on the order of a doctor.		

# The new placement instrument

The new placement instrument is now even easier to use. Spring clips hold the implant on the placement instrument when the implant is removed.

Each is available in three lengths with an ISO shaft and is designed for manual use or use with a ratchet.

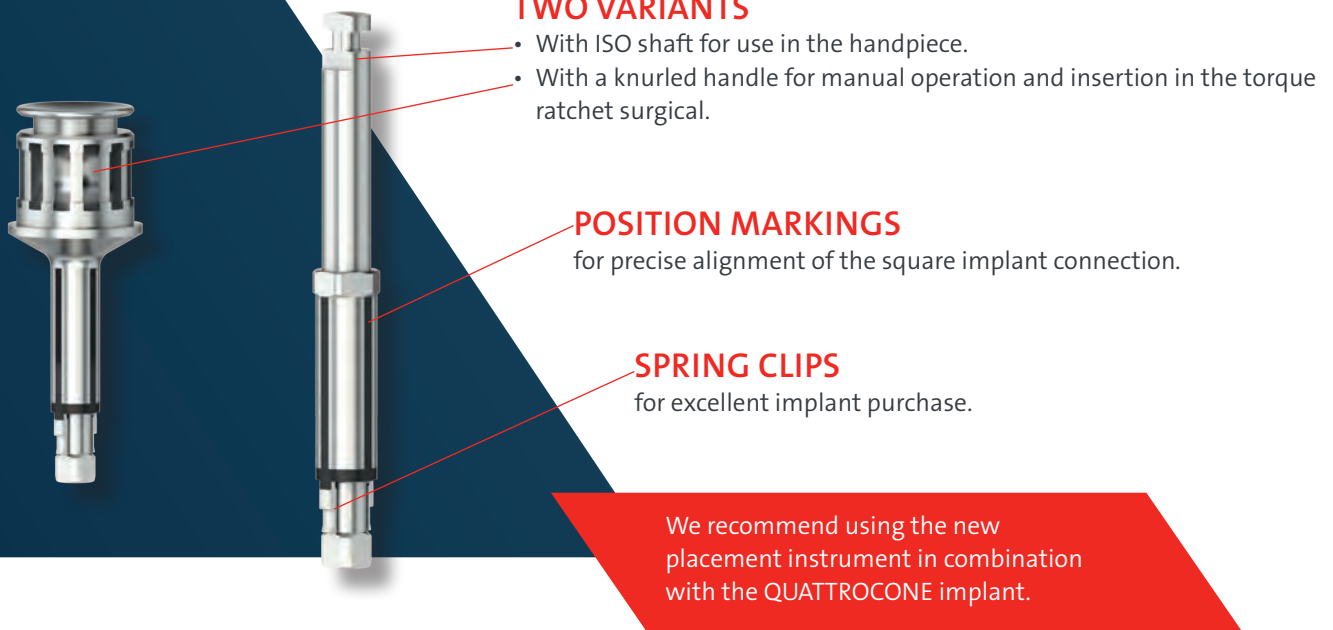

# Torque ratchet surgical

The three-part stainless steel torque ratchet has been especially designed for surgical use. It is easy to handle and can be sterilized assembled.

The torque scale is easy to read and extends from 0 to 45 Ncm.



# Implant removal



Take the blister out of the outer packaging.



Remove the Tyvek film from the blister pack to expose the container with the implant.  
(Caution: This removes the sterile barrier.)



Push down the lid keeping the container upright.

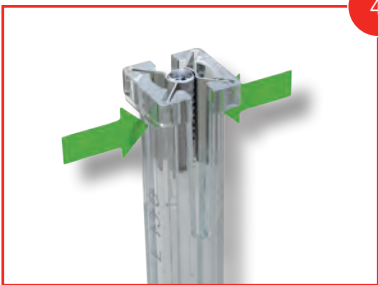

Secure the implant by slightly pressing on the sides of the container.

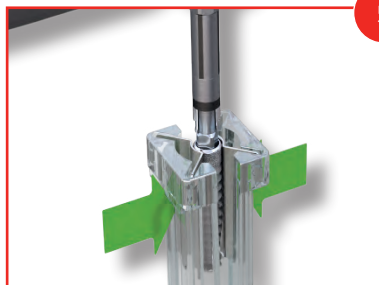

Turn the placement instrument clockwise slowly while inserting it into the implant until it slides into the square of the implant.



A "soft-click" signals that the implant is securely fixed in the placement instrument.

**Please note:**  
**No pressure needs to be applied.**

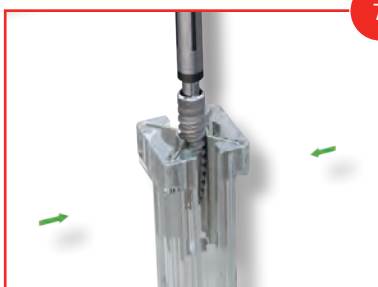

Before removing the implant, release the side pressure on the container.



You can now safely remove the implant.



Screw the implant into the prepared implant bed.

A detailed drilling protocol is available on page 34

## REMOVING THE CLOSURE SCREW



The included closure screw is on the underside of the container.  
**Not with QUATTROCONE30**



Use the HEX 1.26 placement instrument to remove the closure screw. Unscrew the closure screw from the container.





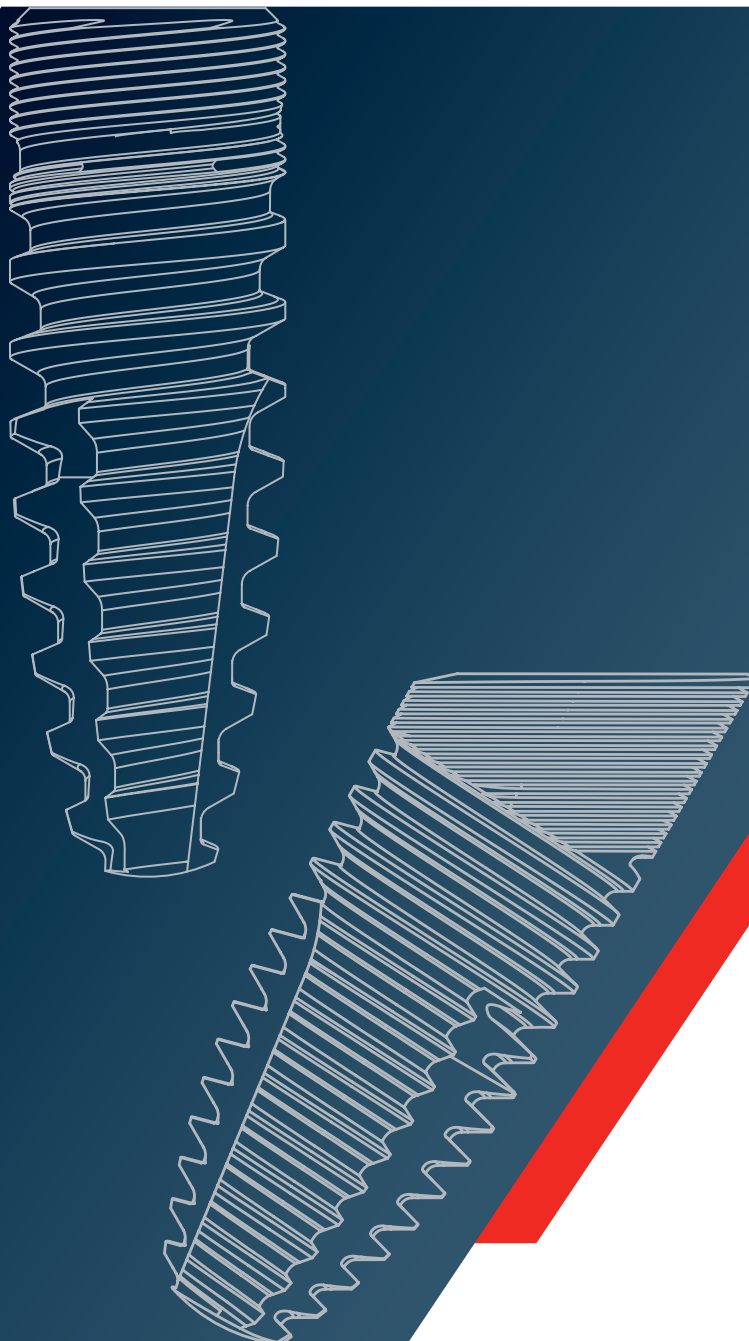











Turn the closure screw hand tight (5-10 Ncm).



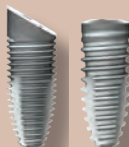

# The drilling protocol

Marker with needle drill	Pilot drill	Implant diameter	Incremental drilling	Final drilling	Cortical drill for D1/D2 bone quality
 1.6 mm	 2.0 mm*	 D 3.5		 3.2 mm*	 3.3 mm*
		 D 3.8		 3.5 mm*	 3.6 mm*
		 D 4.3		 4.0 mm*	 4.1 mm*
		 D 5.0	 4.0 mm*	 4.7 mm*	 4.8 mm*

\*Drill diameter

The recommended drill speed is 300-600 rpm. The maximum speed of 800 rpm should not be exceeded. Replace the drill bit after no more than 30 uses. Irrespective of this, the condition of the drill bit must be checked before and after each use\* to ensure it is in perfect condition and replaced where necessary.

# QUATTROCONE

## Implant bed preparation

### Incision phase



The incision phase serves to form a mucosa flap to reveal the implantation point as bone. This incision phase is case-dependent and must be considered based on the patient's individual requirements and the healing mode (submerged or open healing).

### First marker drill with the needle drill Ø 1.6 mm



The marker drill is inserted following the mobilization of the mucoperiosteal flap with the needle drill and can also alternatively be performed with the aid of a drilling template.

### Pilot drill hole with the pilot drill Ø 2.0 mm



The pilot hole is drilled with the Ø 2.0 mm pilot drill. This defines the sagittal direction of the implant axis and the drilling depth (observe depth marking). A template-based implantation is recommended for the definitive alignment and to prevent deviations from the implant planning.

While drilling it is essential to ensure sufficient cooling, e.g. NaCl liquid, to avoid overheating and thus damage to the bone.

### Reaming with the standard drill (pink) Ø 2.0 / 3.2 (optional)



In this case, reaming is initially carried out with the standard drill Ø 2.0 / 3.2 mm. The laser markings that correspond to the respective implant length serve to inspect the depths for their part.

### Reaming with standard drill (purple) Ø 2.0 / 3.2 / 4.0 mm



The final reaming is completed using the standard drill Ø 2.0 / 3.2 / 4.0 mm.

### Reaming with the cortical drill (purple/red) Ø 2.5 / 4.0 / 4.1 mm



It is recommended in the event of an extremely compact cortex and an average spongiosa or D1/D2 bone quality in the lower jaw using additionally the cortical drill with a diameter of 2.5 / 4.0 / 4.1 mm.

# Implant insertion

## Implant placement with the contral angled handpiece

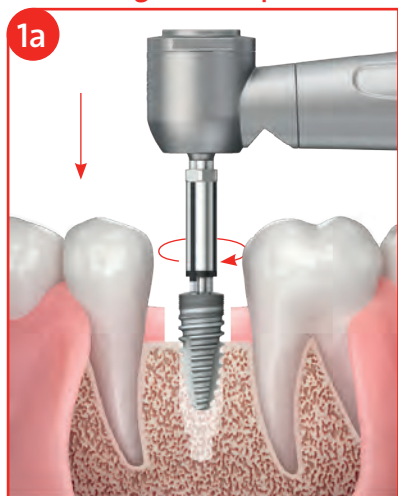

If the implant is inserted with the placement instrument for the angled handpiece, a max. number of 25 rpm and a torque of 35 Ncm should not be exceeded. However, if 35 Ncm is not sufficient to reach the final implant position, carefully unscrew the implant and enlarge the implant bed with the cortical drill (see implant bed preparation).

## Final positioning with the torque ratchet surgical



If the implant is inserted with the torque ratchet surgical and the manual insertion instrument, the torque should not exceed 35 Ncm. If the torque is insufficient, we recommend carefully unscrewing the implant and then widening the implant bed with the cortical drill (see implant bed preparation).

## Remove the placement instrument



Once the implant has reached its final position, the placement instrument should be carefully removed from the implant (either with the handpiece or the ratchet).

## Subcrestal implant position

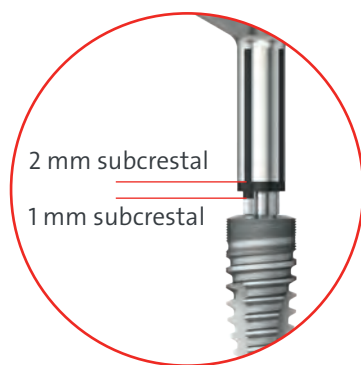
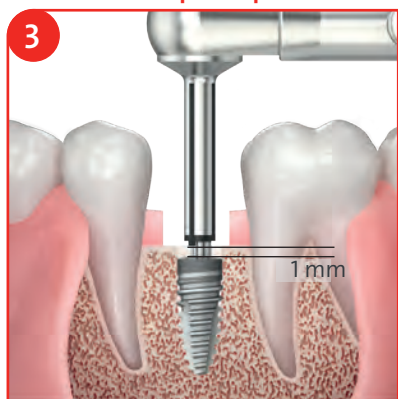

Due to the internal tapered connection the implant can be inserted approx. 1 mm subcrestally if there is a sufficient amount of bone in a vertical direction, in order to stabilise the periimplant bone better. Such a procedure ensures unencumbered healing even under the mucosa supported dentures and can improve the prosthetic results in esthetically relevant area if there is not enough soft tissue available.

In the case of the pre-surgical planning and the observation of the laser marking of the bit you must ensure the subcrestal implant position has been planned in advance.

For depth control during subcrestal placement, laser markings are provided on the insertion instrument.

## Paralleling aid



The paralleling aid can be used for orienting to the selected implant axis when inserting several implants.

This can be performed either by placing the paralleling aid in the implant bed or by placing the paralleling aid directly in the implant.

**NOTE:**

The plugged connection between the implant and the placement instrument means that it is not possible during an open sinus lift operation, for example, to pull the implant back if required, as this could release this connection.

In unfavorable cases there is a risk that an implant could be displaced in the maxillary sinus. Complex surgical measures would then have to be taken to recover the implant.

**FURTHER TREATMENT**

## Option 1: Transgingival healing

### Insertion of the gingiva former

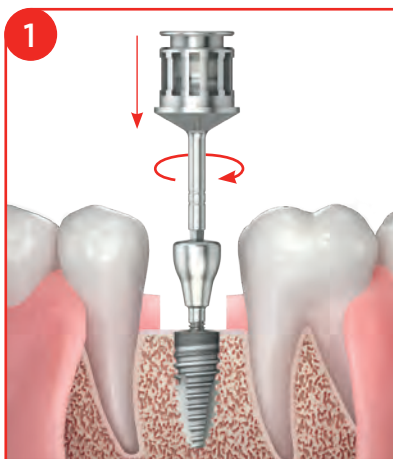

If the implant is intended for transgingival healing, the gingiva former must be inserted in accordance with the thickness of the soft tissue following the removal of the placement instrument.

The diameter of the gingiva former must be selected in accordance with the prosthetic requirements.

### Wound closure



The wound edges adapted by sutures to the gingival tension free but saliva close by sutures.

**PLEASE NOTE:**

If the patient has a temporary restoration with a partial or full prosthesis, ensure that there is no contact with the gingiva former or the temporary restoration.

# Option 2: Submerged healing

## Inserting the closure screw

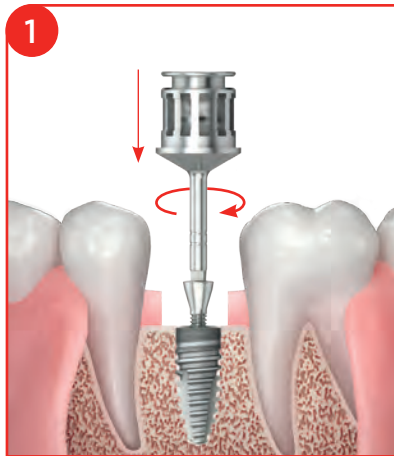

If the implant is intended for submerged healing, the closure screw must be inserted hand tight with the Hex 1.26 hand instrument following the removal of the placement instrument implant.

## Wound closure

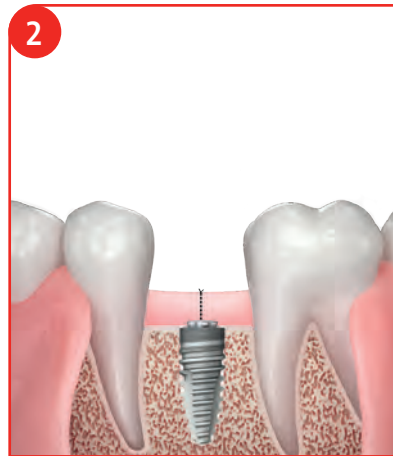

The alveolar ridge is closed by sutures to prevent ingress of saliva. The suturing should ideally be free of tension. To document the final implant position, a post operation X-ray could be done. A load-free healing phase must be ensured.

## Incision



Following the localization of the implant and the point-based anesthetic directly above the implant a limited crestal cut is performed to the implant surface.

## Uncovering



The central interior hex of the closure screw is found with the probe. Connective tissue or bone must be removed with the sharp curette above the locking closer screw. Bones which disrupt the emergence profile must be removed.

## Removal of the closure screw

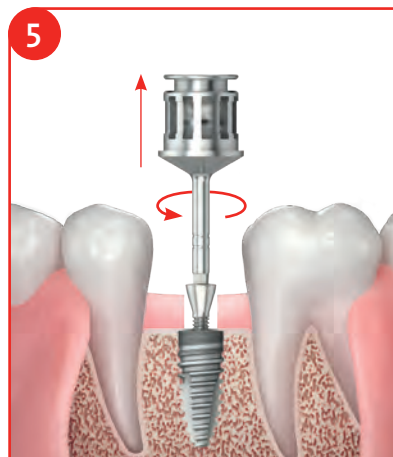

The closure screw must be removed with the Hex 1.26 hand instrument.

## Insertion of the gingiva former

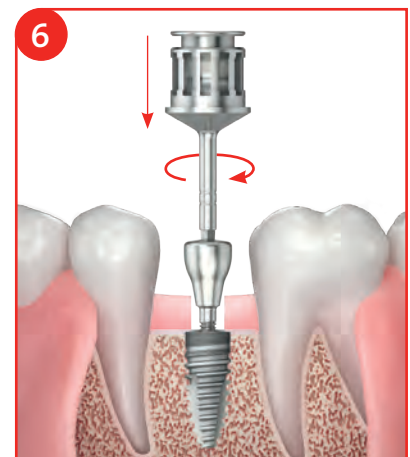

In accordance with the prosthetic requirements, the gingiva former that fits must be screwed in with the Hex 1.26 hand instrument. If necessary, adapt the wound margins to the gingiva former and secure with sutures.



## Option 3: Immediate restoration with a provisional

If the clinical conditions allow an immediate restoration, the patient could get immediately after insertion of the implants an implant-supported denture by using the temporary abutment.

It must be pointed out, that the temporary restoration has to stand out of occlusion so the implant can heal unloaded. The surgeon is responsible for explaining to the patient how load-free implant healing can be achieved postoperatively.



### Preparing the temporary restoration

The temporary restoration is manufactured on the temporary abutment. The grinding operation should be performed outside of the mouth.

Temporary abutments with an emergence diameter of 5.5 mm, straight and angled, are available to ensure easy individualization.

Furthermore, temporary abutments are available as a metal base, which are used for additive procedures.



### Insertion of the temporary restoration

Before inserting the temporary restoration, the interface of the implant should be cleaned with an air/water spray. The abutment is then inserted with a torque ratchet or a torque-controlled angled handpiece at 25 Ncm. For cemented restorations the use of provisional cementum is recommended. Remove all excess cement from the margin of the crown. Ensure that the wound is closed to prevent ingress of saliva.

#### PLEASE NOTE:

Temporary restorations must be replaced after six months at the latest.

### Loads

The precondition for immediate stressing is primary stability that is greater than or equal to 35 Ncm. The possibility of excess stress through the temporary restoration should be ruled out. No occlusion or articulation contacts may be present. An insertion torque of at least 35 Ncm during the initial healing phase reduces the risk of macromovements at the implant bone boundary, for instance through tongue or cheek pressure.

Studies<sup>1,2</sup> demonstrate that micromovements up to a threshold value of approx. 150 µm are tolerated during the osseointegration of dental implants.

Successful osseointegration can also take place in the event of “non-functional immediate stress” subject to the precondition that this value is not exceeded and all the other requirements are fulfilled.

<sup>1</sup> Brunski JB: *Biomechanical factors affecting the bone-dental implant interface.*

*Clin Mater* 1992; 10 (3): 153–201

<sup>2</sup> Brunski JB: *Avoid pitfalls overloading and micromotions of intraosseous implants.*

*Dent Implantol Update* 1993; 4 (10): 77–81

# QUATTROCONE30

## Implant bed preparation

Example for QUATTROCONE30 D 4.3 x L 11.0

The first drill hole for the straight implant is drilled into the upper or lower jaw with a pilot drill. Once the tip of the drill aid is positioned in this drill hole, it can be aligned according to the clinical requirements. Once secured, it is used as a drill guide. This ensures that drilling is exactly at an angle of 30°.

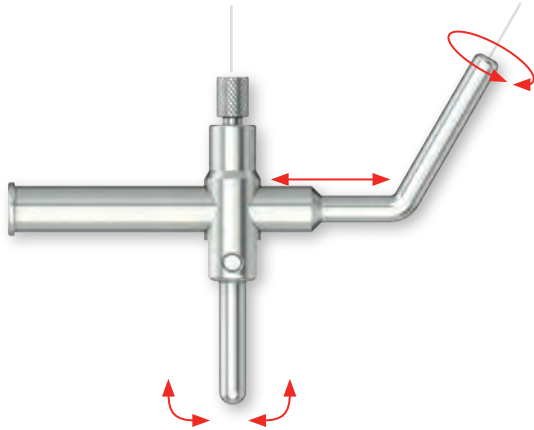

### Drill aid QUATTROCONE30

This is used during implant preparation based on the QuattroFix concept to establish the exact angle for drilling. The length of the drill aid is flexible and it can be rotated in three axes.

Art. No. 4-13-07

While drilling it is essential to ensure sufficient cooling, e.g. NaCl liquid, to avoid overheating and thus damage to the bone.

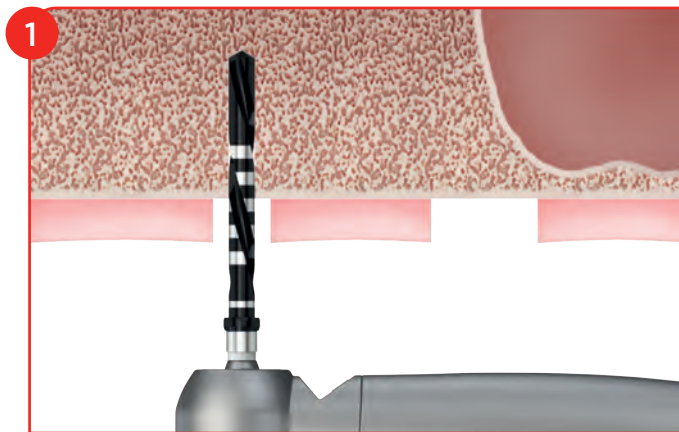

### Implant bed preparation

Preparing the later implant bed for the straight implant with the pilot drill. Minimum drill depth 9 mm.

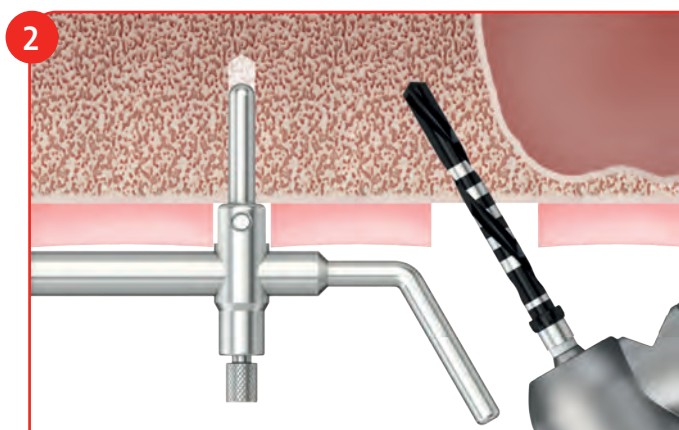

### Inserting the drill aids

Insert the QUATTROCONE30 drill aid and prepare the implant bed for the QUATTROCONE30 implant with the pilot drill to the required implant length.

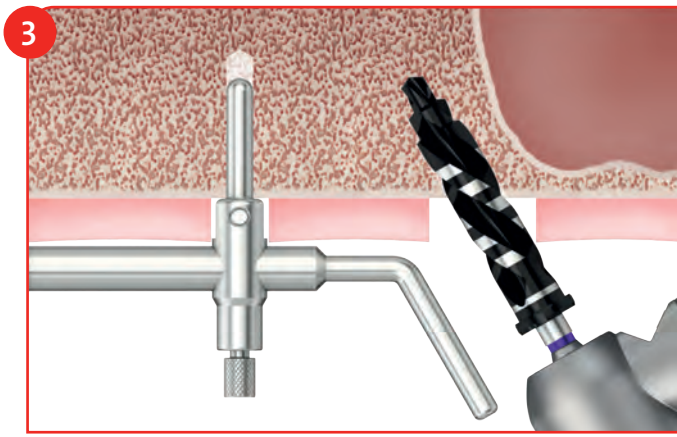

### Enlarging the implant bed

Enlarge the implant bed with the final drill according to the implant diameter.

## Implant insertion

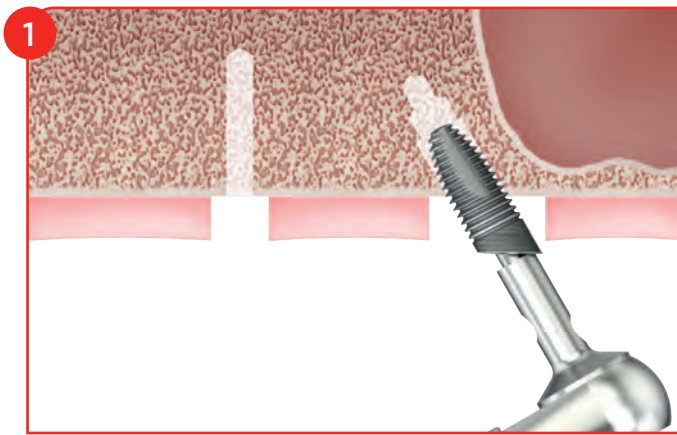

### Inserting the implant

The implant is inserted with the placement instrument (manually with a ratchet or the angled handpiece) without exceeding the maximum torque of 35 Ncm. However, if this torque of 35 Ncm has to be exceeded in order to achieve the final implant position, carefully unscrew the implant and enlarge the implant bed with the cortical drill.

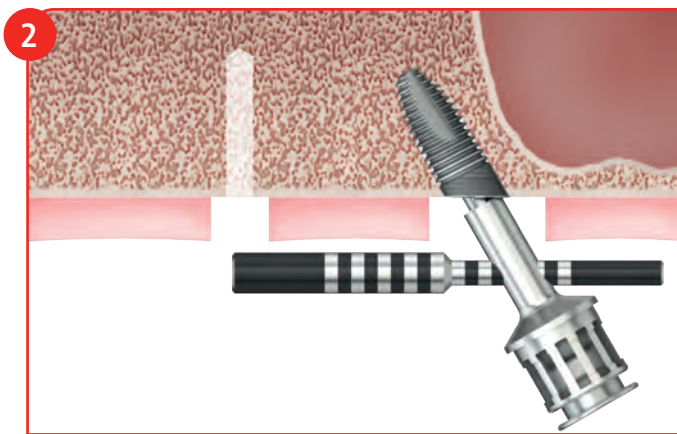

### Paralleling aid

For the correct insertion of the QUATTROCONE30 implant, you can use the parallelization guide to check the 30° axis and the correct alignment of the prosthetic axis on the alveolar ridge.

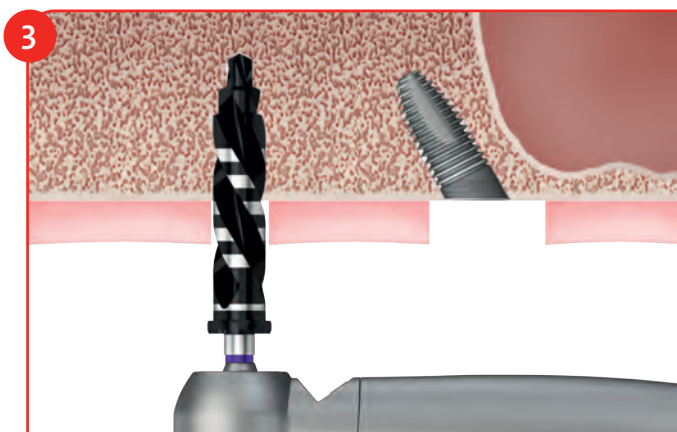

### Enlarging the implant bed

After inserting the angled QUATTROCONE30 implant, enlarge the implant bed with the final drill based on the implant diameter of the straight QUATTROCONE implants.

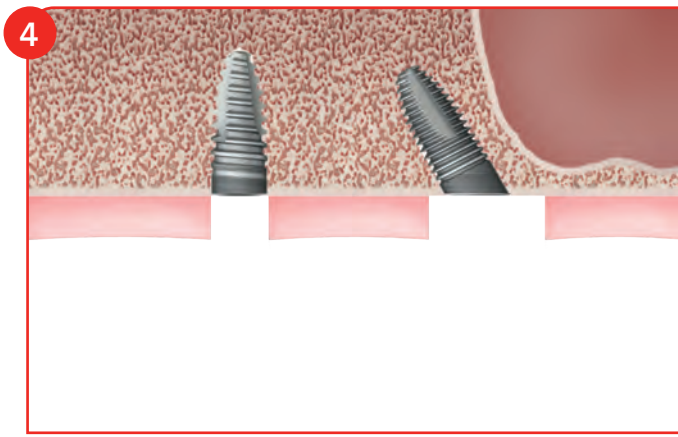

### QuattroFix

Straight and angled implants inserted in the correct ratio for the QuattroFix treatment.

## Inserting the abutment

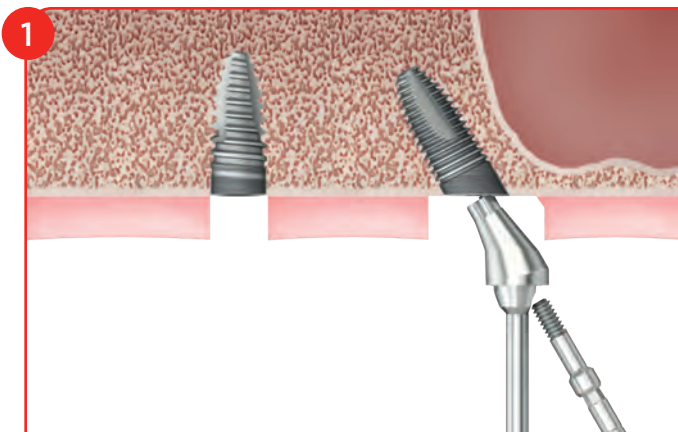

### Multi-unit abutment 30°

After inserting the implant, the 30° angled multi-unit abutment is connected to the implant with the special insertion aid.

Once the abutment is positioned, it is tightened with the screw with a maximum torque of 25 Ncm.

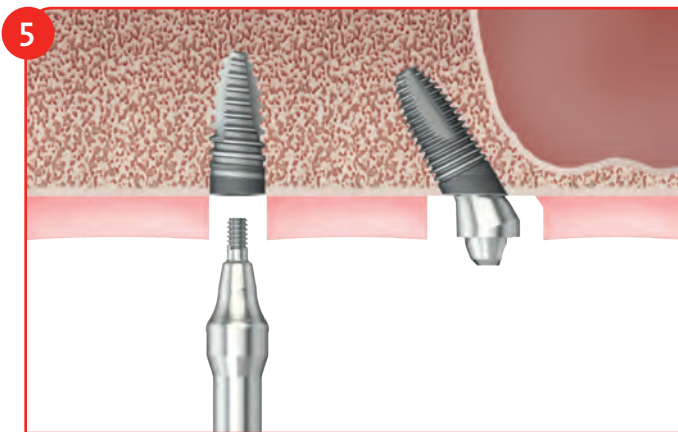

### Straight multi-unit abutment

The straight multi-unit abutment is screwed into the implant with the placement instrument 0-13-76.

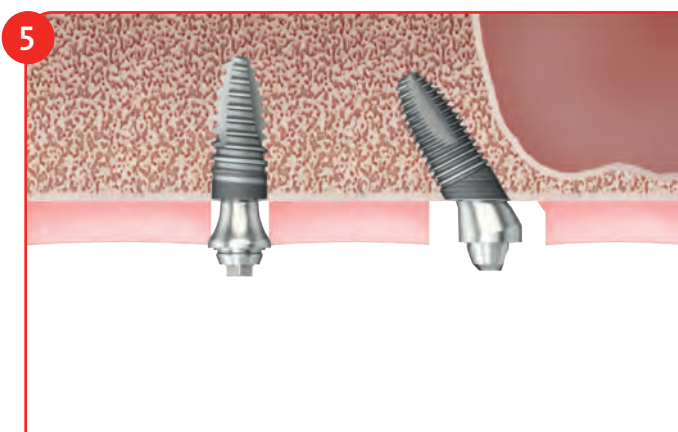

### Final situation

Once the multi-unit abutment has been positioned, the restoration treatment is continued.



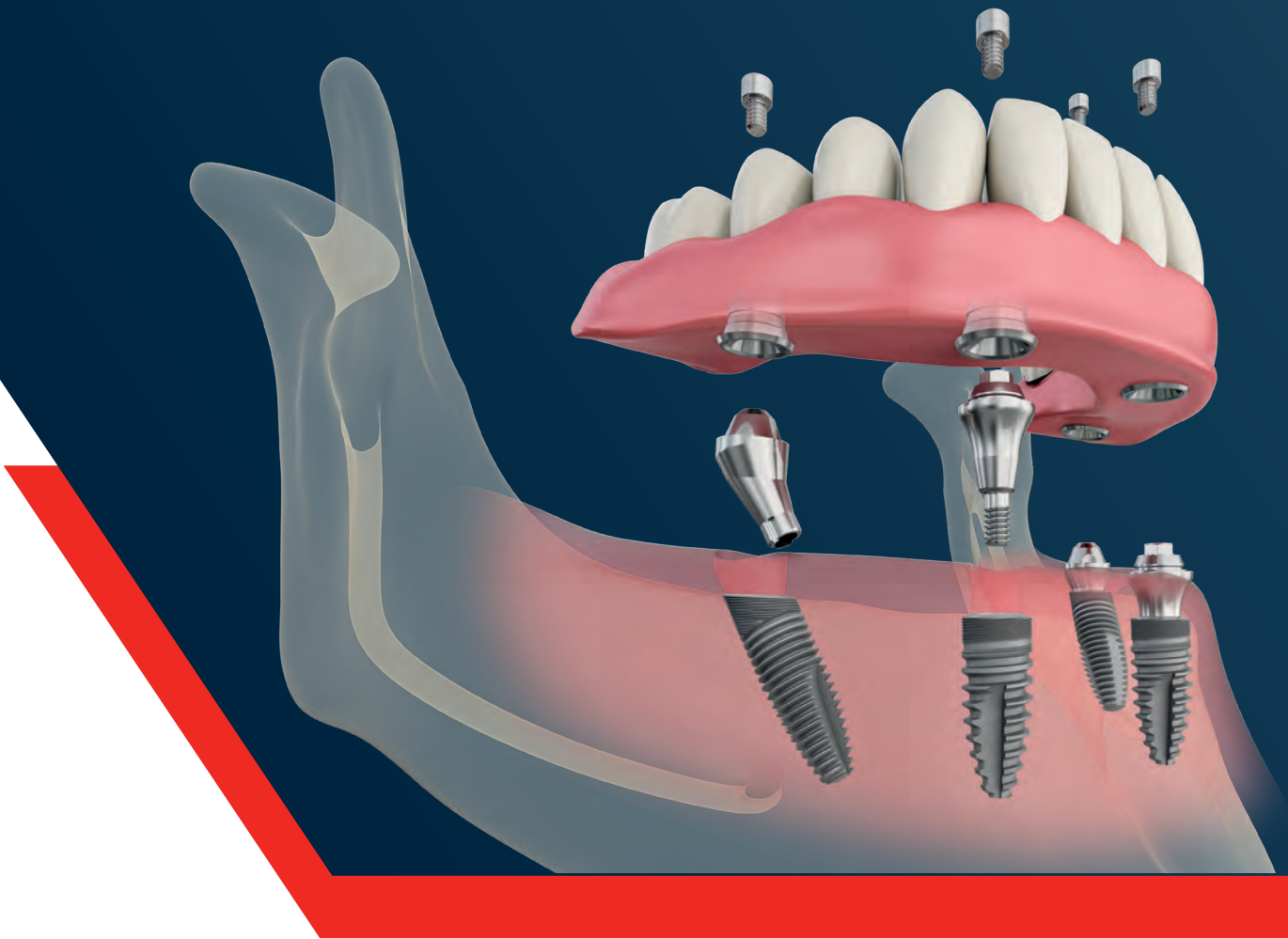

# Clinical examples of QuattroFix



Initial situation

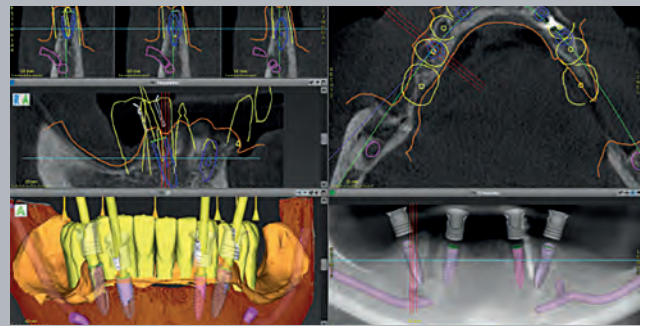

3D planning

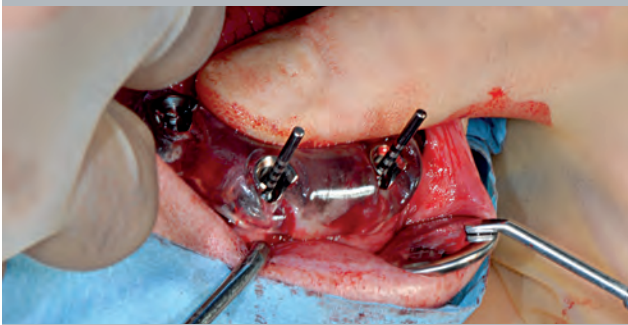

Check the implant bed

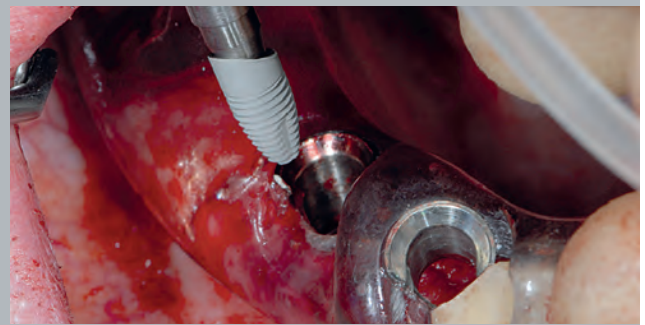

Insert the implant

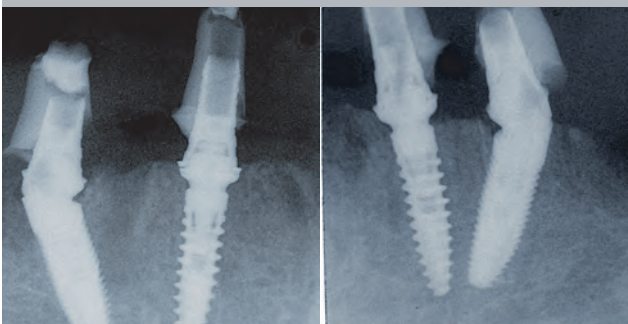

X-ray image



Position the abutment

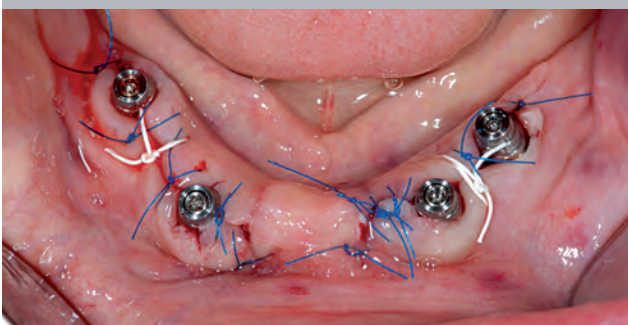

Situation after suture closure



Temporary restoration



Situation after healing time



Milled zirconium bridge



Final restoration



Final situation



Clinical case:  
Dr. med. dent. Martin Müllauer



## Functional bone adaptation to angulation

Abboud M, Rugova S  
 Department of Prosthodontics  
 Stony Brook University, School of Dentistry

### Introduction

Conventional implants placed in 25-45 degree angulation have provided a significant alternative for the restoration of maxillary and mandibular posterior segments in order to overcome anatomical constraints. Based on the available clinical studies, the tilted implants are not subject to a higher implant failure rate, but there are strong indications from in-vitro and in-vivo studies that increased stress patterns and tipping of the tilted implant during loading negatively affect crestal bone remodeling. This can lead to ongoing crestal bone loss<sup>1</sup> over time, by itself increasing the risk for peri-implant diseases.

### Methods

The study was approved by Ethical Committee of Murcia University, Spain. Six adult Fox Hound dogs have been used in this experiment. All 3 mandibular premolars and the first molar of each dog were extracted and 4 conventional implants (Medentika Implants GmbH, Huegelsheim; Germany) were immediately inserted straight and 4 newly designed tilted implant (Quattrocone, Medentika Implants GmbH, Germany) were inserted in a 30 degree angulation.



Fig 1: All implants are placed using a surgical guide (left). The two newly designed implants are placed in a 30 degree angle to the distal (right).

In the first group the immediate loading of the implants was performed with a bar. In the second group the implants were inserted in the extraction sockets without loading and after 3 months of healing the implants were loaded with a bar for another 3 months. Radiographs were obtained from all implant sites following implant installation, and after 3 and 6 months. The animals were sacrificed and biopsies from all implant sites were obtained and prepared for histological analysis.



Fig 2: The straight and angulated implants are placed epicrestally (left). Implants in Group 1+2 are connected with a metal bar (SFI bar) and immediately loaded (right).



Fig 3: Radiographs after immediate implant placement in extraction sockets.

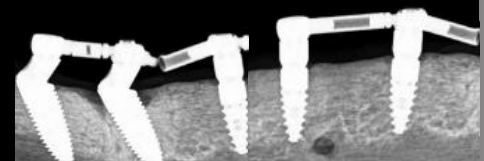

Fig 4: Radiographs 3 months after placement in dog 1. Due to overload only localised crestal bone loss resulted at the surrounding bone.

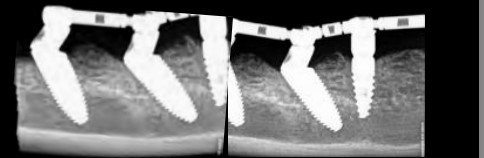

Fig 5: Radiographs 3 months after placement in dog 2. Crestal bone was maintained around the straight and tilted implants.

### Res

The radiographic analysis revealed that bone loss occurred following implant installation. The most pronounced alterations that were observed at implants without functional load were small and did not differ between groups. The histological analysis revealed a Bone-Contact (BIC) of 63.48% with values that were exposed to functional load exhibited higher BIC than implants without loading. There was no significant difference regarding the newly designed tilted implants compared to the conventional implants.



The QUATTROCONE project is based on years of science and development of optimal implant screw geometries for immediate loading and implant placement by Professor Dr. M. Abboud (State University of New York Stony Brook, USA). Medentika® has integrated the patented design components into a novel implant with a unique approach to the indications of angulated insertion including QuattroFix.

## Angulated and straight implant placement

Dr. SH, Calvo Guirado JL

Oral Maxillofacial Surgery and Digital Technology  
Dental Medicine, Stony Brook, NY

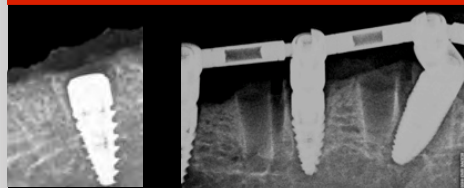

Fig 5: Radiographs showing implant placement in dog 1.

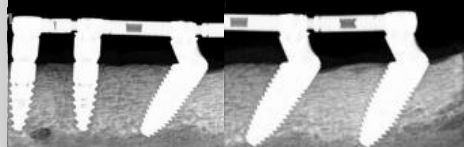

Fig 6: Radiographs showing metal bar fracture due to excessive loading of implants.

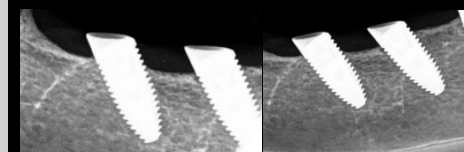

Fig 6: Radiographs 3 months after placement in dog 3 without immediate loading. Crestal bone loss occurred around all of these implants.

## Results

That the largest amount of bone loss occurred around implants placed without immediate loading. The bone level around implants exposed to 3 months of non-loading did not differ significantly between the control and the tilted implants. The average Bone-to-Implant Contact (BIC) was 43.39% to 92.05%. Implants placed in a higher degree of BIC than control implants. There was no significant difference in bone loss around implants placed in a 30 degree angulation compared to conventional implants placed straight.

## Conclusions

Based on the radiologic analysis and the histology results it can be concluded that the newly designed implants placed in a 30 degree angulation show similar cortical bone maintenance with immediate placement and immediate loading compared to conventional implants placed straight. It is suggested that functional load at implants may enhance osseointegration and result in a higher BIC and improved marginal bone stability. It should be expected that implants placed without functional load have an increased risk of crestal bone resorption.

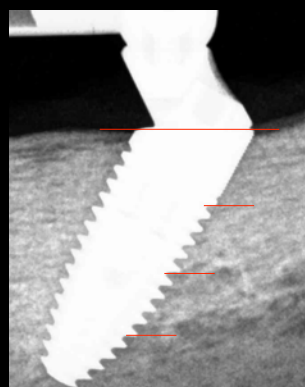

Fig 7: Patented macrothread design parallel to the implant shoulder prevent tilting and successfully maintain the crestal bone level.

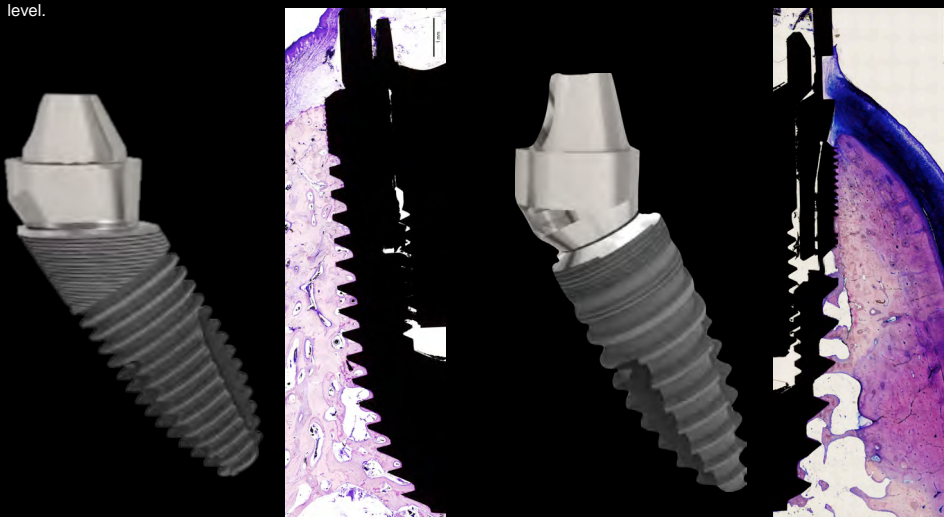



Fig 8: Histology of the conventional implant (right) showed similar results to the newly designed tilted implants (left).

The smaller macro-thread pitch, the tapered implant body design for increased primary stability, the self-cutting macro- and the ideal force distribution of the macro-threads make the newly designed implant an optimal device for the angulated insertion and the All-on-4® concept.

Acknowledgement: Special thanks to Medentika Implant GmbH, Germany for the production of the implants and drill bits



## Functional Bone Response for Angulated Placed Implants Compared to Straight Implants

Abbad M, Rugova H, Calvo Guirado JL  
 Department of Prosthodontics and Digital Technology  
 Stony Brook University, School of Dental Medicine, Stony Brook, NY, USA

### Introduction

Conventional implants placed in 25-45 degree angulation have provided a significant alternative for the restoration of maxillary and mandibular posterior segments in order to overcome anatomical constraints. Based on the available clinical studies, the tilted implants are not subject to a higher implant failure rate, but there are strong indications from in-vitro and in-vivo studies that increased stress patterns and tipping of the tilted implant during loading negatively affect crestal bone remodeling. This can lead to ongoing crestal bone loss<sup>1</sup> over time, by itself increasing the risk for peri-implant diseases.

### Aim/Hypothesis

The aim of this study is to create a new dental implant design for the All-on-4® concept that minimizes the stress on the bone-implant interface while successfully preventing tipping of the implant during loading, resulting in favorable cortical bone maintenance. The patented micro-threads at the top of the newly designed 30° tilted implant are parallel to the implant shoulder as well as the patented self-cutting macro-threads.

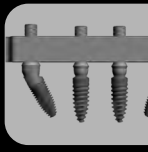
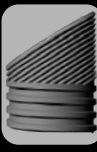



Fig 1: Two centrally placed auxiliary implants, which are supported by two tilted implants, are placed in a 30 degree angle to the distal allow a fixed restoration on only 4 implants.

Fig 2: The special patented macro-threads and micro design allows an even 25°-30 degree to the distal allow a fixed restoration on only 4 implants.

### Materials





Fig 3: All implants are placed using a surgical guide (left). The two newly designed implants are placed in a 30 degree angle to the distal (right).

The protocol was approved by the Ethical Committee of Murcia University, Spain. In 3 fox hound dogs 4 newly designed Quattrocone 30 implants (Medentika Implants GmbH, Germany) were immediately placed in extraction sockets in a 30° angulation (Fig. 3) and 4 conventional Quattrocone implants (Medentika Implants GmbH) were placed straight. In total 24 implants were placed. Radiographs were obtained following implant installation and 3 months. Histology was taken after 3 months.

<p><b>Group 1:</b> 8 straight implants placed in extraction sockets, immediate loading of implants performed with a bar</p> <p><b>Group 2:</b> 8 tilted implants placed in extraction sockets, immediate loading of implants performed with a bar</p>	<p><b>Group 3:</b> 4 straight Implants placed in extraction sockets without loading</p> <p><b>Group 4:</b> 4 tilted implants placed in extraction sockets without loading</p>
---	---





Fig 4: The straight and angulated implants are placed epicrostally (left). Implants in Group 1+2 are connected with a metal bar (SF) bar and immediately loaded (right).

Fig 5: The different design of the conventional straight implant (left) compared to the newly designed implant optimized for angulated placement (right).

### Results

There was no significant difference in bone loss regarding the newly designed implants placed in a 30 degree angulation (Fig. 9) compared to the conventional implants placed straight. The radiographic analysis revealed the largest amount of bone loss following implant installation. This bone loss was more pronounced at implants in Group 3 & 4 without immediate loading (Fig. 8). The implant bone level alterations after 3 months of functional load in Group 1 & 2 did not differ significantly between the groups (Fig. 6, 7). The histological analysis revealed an average Bone-to-Implant Contact (BIC) of 63.48% with values between 43.39% to 92.05%. Implants exposed to functional load exhibited a higher degree of BIC than control implants without loading. The average bone loss was 1.11mm after 3 months for all implants.

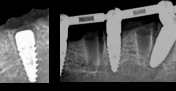



Fig 5: Radiographs after immediate implant placement in extraction sockets and immediate loading in dog 1.

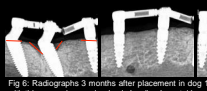
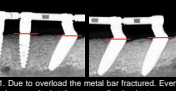



Fig 6: Radiographs 3 months after placement in dog 1. Due to overload the metal bar fractured. Even with this excessive overload only localized crestal bone loss resulted at the surrounding implants.

Fig 7: Radiographs 3 months after placement in dog 2. Crestal bone was maintained around the straight and tilted implants.

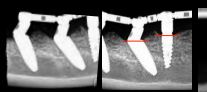



Fig 8: Radiographs 3 months after placement in dog 3 without immediate loading. Crestal bone loss occurred around all of these implants.

Fig 9: Patented macrothread design parallel to the implant shoulder prevents tilting and successfully maintains the crestal bone level.

### Conclusions

Based on the radiologic analysis and the histology results it can be concluded:

- The newly designed Quattrocone 30 implants inserted in a 30 degree angle show comparable cortical bone levels with immediate placement and immediate loading as conventional implants placed straight.
- Functional loading seems to enhance the osseointegration and resulted in a higher BIC and improved marginal bone stability. It should be expected that placing implants without any functional load has an increased risk of crestal bone resorption.

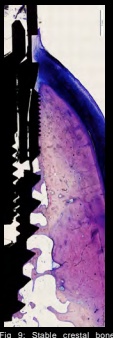



Fig 9: Stable crestal bone level after immediate placement and immediate loading.

The smaller thread pitch of the Quattrocone 30 implant for increased bone-to-implant contact, the tapered implant body design for increased primary stability, the self-cutting thread design and the ideal force distribution of the optimized macro-threads make this newly designed implant an optimal device for the angulated insertion. Especially in an All-on-4® indication with immediate loading or function this new implant seems to perform very well.

### References

1: Brownsays, H., Dierens, M., Ruyffelaert, C., Matthijs, C., De Bruyn, H. and Vandeweghe, S. (2014). Ongoing Crestal Bone Loss around Implants Subjected to Computer-Guided Flapless Surgery and Immediate Loading Using the All-on-4® Concept. *Clinical Implant, Dentistry and Related Research*. doi:10.1111/cid.12197

Research Grant from Medentika Implants GmbH, Huegelshelm, Germany

2016 AADR/CADR Annual Meeting & Exhibition



## Publications

1. Rugova SH, Abboud M. Standardized Procedure for Implant Bed Preparation Testing. Int J Oral Maxillofac Implants, submitted 2016
2. Abboud M, Delgado-Ruiz RA, Kucine A, Rugova S, Balanta J, Calvo-Guirado JL. Multi-stepped Drill Design for Single-Stage Implant Site Preparation: Experimental Study in Type 2 Bone. Clin Implant Dent Relat Res. 2015 Oct;17 Suppl 2:e472-85. doi: 10.1111/cid.12273. Epub 2014 Sep 29.

## Abstracts

1. Abboud M, Rugova S, Calvo-Guirado J. Bone reactions to functional load: Histological and radiographic evaluation. European Association of Implantology (EAO) 2015, Clin. Oral Impl. Res. 25 (Suppl. 10), 2015
2. Abboud M, Calvo-Guirado J. New tilted implant design: an experimental study in dogs. European Association of Implantology (EAO) 2014, Clin. Oral Impl. Res. 25 (Suppl. 10), 2014
3. Abboud M, Rugova S, Delgado-Ruiz R, Kucine A. The effect of simplifying the dental implant drilling sequence on bone trauma. European Association of Implantology (EAO) 2014, Clin. Oral Impl. Res. 25 (Suppl. 10), 2014
4. Rashford R, Luxenberg A, Abboud M. Fiducial marker for guided surgery systems. Academy of Osseointegration (AO), 28th Annual Meeting, March 5-7, 2014
5. Luxenberg A, Rashford R, Abboud M. An open drill guide system. Academy of Osseointegration (AO), 28th Annual Meeting March 5-7, 2014
6. Rugova SH, Delgado-Ruiz A, Kucine A, Abboud M. Evaluation of a new 1-step implant drill bit. Academy of Osseointegration (AO), 28th Annual Meeting, March 5-7, 2014
7. Abboud M, Steinberg M, Delgado-Ruiz R, Won A. Standardized primary implant stability with a new implant drill design. EAO Annual Meeting 2013, Dublin, Ireland

## QUATTROCONE implant

D 3.5 mm

- D 3.5
- Titanium Grade 4
- Sterile packaged
- Incl. closure screw



Length	9 mm	11 mm	13 mm	15 mm
Implant connection	RI	RI	RI	RI
Article No.	3-01-02	3-01-03	3-01-04	3-01-05

## QUATTROCONE implant

D 3.8 mm

- D 3.8
- Titanium Grade 4
- Sterile packaged
- Incl. closure screw



Length	7 mm	9 mm	11 mm	13 mm	15 mm
Implant connection	RI	RI	RI	RI	RI
Article No.	3-01-16	3-01-17	3-01-18	3-01-19	3-01-20

## QUATTROCONE implant

D 4.3 mm

- D 4.3
- Titanium Grade 4
- Sterile packaged
- Incl. closure screw



Length	7 mm	9 mm	11 mm	13 mm	15 mm
Implant connection	RI	RI	RI	RI	RI
Article No.	3-01-06	3-01-07	3-01-08	3-01-09	3-01-10

## QUATTROCONE30 implant

D 4.3 mm

- angled
- D 4.3
- Titanium Grade 4
- Sterile packaged



Length	9 mm	11 mm	13 mm	15 mm
Implant connection	AI	AI	AI	AI
Article No.	4-01-01	4-01-02	4-01-03	4-01-04

## QUATTROCONE implant

D 5.0 mm

- D 5.0
- Titanium Grade 4
- Sterile packaged
- Incl. closure screw



Length	7 mm	9 mm	11 mm	13 mm	15 mm
Implant connection	RI	RI	RI	RI	RI
Article No.	3-01-11	3-01-12	3-01-13	3-01-14	3-01-15



## QUATTROCONE30 implant

D 5.0 mm

- angled
- D 5.0
- Titanium Grade 4
- Sterile packaged



Length	9 mm	11 mm	13 mm	15 mm
Implant connection	AI	AI	AI	AI
Article No.	4-01-06	4-01-07	4-01-08	4-01-09

## Closure screw

- Titanium Grade 5 CF
- Sterile packaged



Implant connection	RI	AI
Article No.	2-02-01	4-02-01

## Gingiva former

- D 3.0
- Titanium Grade 5 CF
- Sterile packaged



Implant connection	RI
Gingiva height	4.0 mm
Diameter	D 3.0
Article No.	2-03-14

## Gingiva former

- D 4.0
- Titanium Grade 5 CF
- Sterile packaged



Implant connection	RI	RI	RI
Gingiva height	3.0 mm	4.0 mm	6.0 mm
Diameter	D 4.0	D 4.0	D 4.0
Article No.	2-03-18	2-03-19	2-03-20

## Gingiva former

- D 4.5
- Titanium Grade 5 CF
- Sterile packaged



Implant connection	RI	RI	RI	RI	RI
Gingiva height	1.0 mm	2.0 mm	3.0 mm	4.0 mm	6.0 mm
Diameter	D 4.5	D 4.5	D 4.5	D 4.5	D 4.5
Article No.	2-03-02	2-03-03	2-03-15	2-03-04	2-03-05

## Gingiva former

- D 5.5
- Titanium Grade 5 CF
- Sterile packaged



Implant connection	RI	RI	RI	RI	RI
Gingiva height	1.0 mm	2.0 mm	3.0 mm	4.0 mm	6.0 mm
Diameter	D 5.5	D 5.5	D 5.5	D 5.5	D 5.5
Article No.	<b>2-03-06</b>	<b>2-03-07</b>	<b>2-03-16</b>	<b>2-03-08</b>	<b>2-03-09</b>

## Gingiva former

- D 6.5
- Titanium Grade 5 CF
- Sterile packaged



Implant connection	RI	RI	RI	RI	RI
Gingiva height	1.0 mm	2.0 mm	3.0 mm	4.0 mm	6.0 mm
Diameter	D 6.5	D 6.5	D 6.5	D 6.5	D 6.5
Article No.	<b>2-03-10</b>	<b>2-03-11</b>	<b>2-03-17</b>	<b>2-03-12</b>	<b>2-03-13</b>

## Gingiva former

- D 4.8
- Titanium Grade 5 CF
- Sterile packaged



Implant connection	AI	AI	AI
Gingiva height	1.5 mm	3.0 mm	4.5 mm
Diameter	D 4.8	D 4.8	D 4.8
Article No.	<b>4-03-04</b>	<b>4-03-05</b>	<b>4-03-06</b>

## Needle drill

- Stainless steel



Article No.

**0-14-77**

## Round drill

- Stainless steel



Diameter

2.3 mm

Article No.

**0-14-75**

## Drills for QUATTROCONE implant

- Stainless steel
- ADLC coated



Type	Pilot drill	Pilot drill	Pilot drill
Diameter	2.0 mm	2.0 mm	2.0 mm
Version	extra-short	short	long
Length	L 16 mm	L 20 mm	L 25 mm
Article No.	4-14-85	4-14-01	4-14-06

## Drills for QUATTROCONE implant D 3.5

- Stainless steel
- ADLC coated



Type	Standard drill	Cortical drill	Standard drill	Cortical drill	Standard drill	Cortical drill
Diameter (mm)	2.0/3.2	2.3/3.2/3.3	2.0/3.2	2.3/3.2/3.3	2.0/3.2	2.3/3.2/3.3
Version	extra-short	extra-short	short	short	long	long
Length	16 mm	16 mm	20 mm	20 mm	25 mm	25 mm
Article No.	4-14-86	4-14-87	4-14-02	4-14-03	4-14-07	4-14-08

## Drills for QUATTROCONE implant D 3.8

- Stainless steel
- ADLC coated



Type	Standard drill	Cortical drill	Standard drill	Cortical drill	Standard drill	Cortical drill
Diameter (mm)	2.0/3.5	2.3/3.5/3.6	2.0/3.5	2.3/3.5/3.6	2.0/3.5	2.3/3.5/3.6
Version	extra-short	extra-short	short	short	long	long
Length	16 mm	16 mm	20 mm	20 mm	25 mm	25 mm
Article No.	4-14-92	4-14-93	4-14-71	4-14-72	4-14-73	4-14-74

## Drills for QUATTROCONE implant D 4.3

- Stainless steel
- ADLC coated

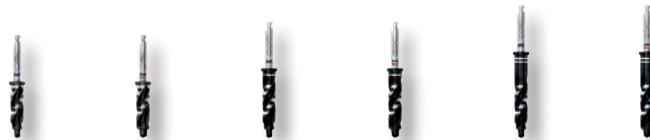

Type	Standard drill	Cortical drill	Standard drill	Cortical drill	Standard drill	Cortical drill
Diameter (mm)	2.0/3.2/4.0	2.5/4.0/4.1	2.0/3.2/4.0	2.5/4.0/4.1	2.0/3.2/4.0	2.5/4.0/4.1
Version	extra-short	extra-short	short	short	long	long
Length	16 mm	16 mm	20 mm	20 mm	25 mm	25 mm
Article No.	4-14-88	4-14-89	4-14-04	4-14-05	4-14-09	4-14-10

## Drills for QUATTROCONE implant D 5.0

- Stainless steel
- ADLC coated



Type	Standard drill	Cortical drill	Standard drill	Cortical drill	Standard drill	Cortical drill
<b>Diameter (mm)</b>	2.9/4.0/4.7	3.6/4.7/4.8	2.9/4.0/4.7	3.6/4.7/4.8	2.9/4.0/4.7	3.6/4.7/4.8
<b>Version</b>	extra-short	extra-short	short	short	long	long
<b>Length</b>	16 mm	16 mm	20 mm	20 mm	25 mm	25 mm
<b>Article No.</b>	<b>4-14-90</b>	<b>4-14-91</b>	<b>4-14-53</b>	<b>4-14-54</b>	<b>4-14-55</b>	<b>4-14-56</b>

## Set extra-short drills

- Stainless steel

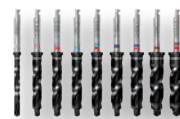

Type	Set				
Article No.	0-13-100				
Set consisting of:	1 pc.	4-14-85	Pilot drill	D 2.0	extra-short
	1 pc.	4-14-86	Standard drill	D 2.0/3.2	extra-short
	1 pc.	4-14-87	Cortical drill	D 2.3/3.2/3.3	extra-short
	1 pc.	4-14-88	Standard drill	D 2.0/3.2/4.0	extra-short
	1 pc.	4-14-89	Cortical drill	D 2.5/4.0/4.1	extra-short
	1 pc.	4-14-90	Standard drill	D 2.9/4.0/4.7	extra-short
	1 pc.	4-14-91	Cortical drill	D 3.6/4.7/4.8	extra-short
	1 pc.	4-14-92	Standard drill	D 2.0/3.5	extra-short
	1 pc.	4-14-93	Cortical drill	D 2.3/3.5/3.6	extra-short

## Set short drills

- Stainless steel



Type	Set				
Article No.	0-13-91				
Set consisting of:	1 pc.	4-14-01	Pilot drill	D 2.0	short
	1 pc.	4-14-02	Standard drill	D 2.0/3.2	short
	1 pc.	4-14-03	Cortical drill	D 2.3/3.2/3.3	short
	1 pc.	4-14-04	Standard drill	D 2.0/3.2/4.0	short
	1 pc.	4-14-05	Cortical drill	D 2.5/4.0/4.1	short
	1 pc.	4-14-53	Standard drill	D 2.9/4.0/4.7	short
	1 pc.	4-14-54	Cortical drill	D 3.6/4.7/4.8	short
	1 pc.	4-14-71	Standard drill	D 2.0/3.5	short
	1 pc.	4-14-72	Cortical drill	D 2.3/3.5/3.6	short



## Set long drills

• Stainless steel

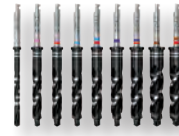

		Type	Set		
		Article No.	0-13-92		
Set consisting of:	1 pc.	4-14-06	Pilot drill	D 2.0	long
	1 pc.	4-14-07	Standard drill	D 2.0/3.2	long
	1 pc.	4-14-08	Cortical drill	D 2.3/3.2/3.3	long
	1 pc.	4-14-09	Standard drill	D 2.0/3.2/4.0	long
	1 pc.	4-14-10	Cortical drill	D 2.5/4.0/4.1	long
	1 pc.	4-14-55	Standard drill	D 2.9/4.0/4.7	long
	1 pc.	4-14-56	Cortical drill	D 3.6/4.7/4.8	long
	1 pc.	4-14-73	Standard drill	D 2.0/3.5	long
	1 pc.	4-14-74	Cortical drill	D 2.3/3.5/3.6	long

## MedentiGuide Outer sleeve standard

• Titanium Grade 5 CF



Diameter (mm)

D 6.3 /  
d 5.01

Article No.

0-32-06

Please note: This sleeve is used for implants D 3.0 - D 4.5.

## MedentiGuide Outer sleeve large

• Titanium Grade 5 CF



Diameter (mm)

D 8.3 /  
d 7.01

Article No.

0-32-07

Please note: This sleeve is used for implants D 5,0.

## MedentiGuide Adapter sleeve

• Titanium Grade 5 CF



Diameter (mm)

D 7.0 /  
d 5.01

Article No.

0-32-08

Please note: This sleeve is used as a connecting piece between the Outer sleeve large and the Inner sleeves for the drill diameter D 2,0 - D 4,0.

## MedentiGuide Inner sleeve QUATTROCONE implant

• Titanium Grade 5 CF  
• Pilot drill



Diameter (mm)

D 5.0 /  
d 2.03

Colour code

grey

Drill diameter

D 2.0 mm

Article No.

0-32-15

## MedentiGuide Inner sleeve QUATTROCONE implant

- Titanium Grade 5 CF
- Standard drill



Diameter (mm)	D 5.0 / d 3.23	D 5.0 / d 3.53	D 5.0 / d 4.03	D 7.0 / d 4.73
Colour code	pink	light blue	purple	brown
Drill diameter	D 3.2 mm	D 3.5 mm	D 4.0 mm	D 4.7 mm
Article No.	<b>0-32-16</b>	<b>0-32-21</b>	<b>0-32-17</b>	<b>0-32-18</b>

## MedentiGuide Inner sleeve QUATTROCONE implant

- Titanium Grade 5 CF
- Cortical drill



Diameter (mm)	D 5.0 / d 3.33	D 5.0 / d 3.63	D 5.0 / d 4.13	D 7.0 / d 4.83
Colour code	pink	light blue	purple	brown
Drill diameter	D 3.3 mm	D 3.6 mm	D 4.1 mm	D 4.8 mm
Article No.	<b>0-32-27</b>	<b>0-32-28</b>	<b>0-32-29</b>	<b>0-32-30</b>

## Placement instrument MedentiGuide

- Stainless steel



Type	Outer sleeve standard	Outer sleeve large
Article No.	<b>0-32-19</b>	<b>0-32-20</b>

## MedentiGuide Placement instrument Implant

- Manual and ratchet
- Hardened stainless steel



Implant connection	AI	AI
Type	QUATTROCONE30	QUATTROCONE30
Version	short	long
Article No.	<b>4-32-09</b>	<b>4-32-10</b>

**Please note:** These insertion tools are used to insert implants when using MedentiGuide sleeves.

## MedentiGuide Placement instrument Implant

- Manual and ratchet
- Hardened stainless steel



Implant connection	RI	RI	RI
Type	QUATTROCONE	QUATTROCONE	QUATTROCONE
Version	extra-short	short	long
Article No.	<b>3-32-12</b>	<b>3-32-09</b>	<b>3-32-10</b>

**Please note:** These insertion tools are used to insert implants when using MedentiGuide sleeves.

## MedentiGuide Placement instrument Implant

- Contra-angle
- Hardened stainless steel



Implant connection	AI	AI
Type	QUATTROCONE30	QUATTROCONE30
Version	short	long
Article No.	<b>4-32-07</b>	<b>4-32-08</b>

Please note: These insertion tools are used to insert implants when using MedentiGuide sleeves.

## MedentiGuide Placement instrument Implant

- Contra-angle
- Hardened stainless steel



Implant connection	RI	RI	RI
Type	QUATTROCONE	QUATTROCONE	QUATTROCONE
Version	extra-short	short	long
Article No.	<b>3-32-11</b>	<b>3-32-07</b>	<b>3-32-08</b>

Please note: These insertion tools are used to insert implants when using MedentiGuide sleeves.

## Tweezers



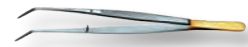



















- diamond coated
- Stainless steel



















Article No. **22.014.03**



















## Drill stops and combination tables

Extra-short drill (16 mm)						
Implant diameter/drill type	Implant length					
	L 7.0	L 9.0	L 11.0	L 13.0	L 15.0	
QUATTROCONE						
 <b>All implant diameters</b> Pilot drill Ø2.0mm 	6 (4-14-16)	4 (4-14-14)	2 (4-14-12)			
 <b>D 3.5</b> Standard/Cortical  	20 (4-14-30)	18 (4-14-28)	16 (4-14-26)			
 <b>D 3.8</b> Standard/Cortical  	59 (4-14-77)	58 (4-14-76)	57 (4-14-75)			
 <b>D 4.3</b> Standard/Cortical  	34 (4-14-44)	32 (4-14-42)	30 (4-14-40)			
 <b>D 5.0</b> Standard/Cortical  	48 (4-14-62)	46 (4-14-60)	44 (4-14-58)			
QUATTROCONE30						
 <b>All implant diameters</b> Pilot drill Ø2.0mm 		3 (4-14-13)	1 (4-14-11)			
 <b>D 4.3</b> Standard/Cortical  		31 (4-14-41)	29 (4-14-39)			
 <b>D 5.0</b> Standard/Cortical  		45 (4-14-59)	43 (4-14-57)			
	Drill stop number					

## Short drill (20 mm)

Implant diameter/drill type		Implant length					
		L 7.0	L 9.0	L 11.0	L 13.0	L 15.0	
QUATTROCONE							
	All implant diameters Pilot drill Ø2.0mm		10 (4-14-20)	8 (4-14-18)	6 (4-14-16)	4 (4-14-14)	2 (4-14-12)
	D 3.5 Standard/Cortical		24 (4-14-34)	22 (4-14-32)	20 (4-14-30)	18 (4-14-28)	16 (4-14-26)
	D 3.8 Standard/Cortical		63 (4-14-81)	61 (4-14-79)	59 (4-14-77)	58 (4-14-76)	57 (4-14-75)
	D 4.3 Standard/Cortical		38 (4-14-48)	36 (4-14-46)	34 (4-14-44)	32 (4-14-42)	30 (4-14-40)
	D 5.0 Standard/Cortical		52 (4-14-66)	50 (4-14-64)	48 (4-14-62)	46 (4-14-60)	44 (4-14-58)
QUATTROCONE30							
	All implant diameters Pilot drill Ø2.0mm		7 (4-14-14)	5 (4-14-15)	3 (4-14-13)	1 (4-14-11)	
	D 4.3 Standard/Cortical		35 (4-14-45)	33 (4-14-43)	31 (4-14-41)	29 (4-14-39)	
	D 5.0 Standard/Cortical		49 (4-14-63)	47 (4-14-61)	45 (4-14-59)	43 (4-14-57)	
Drill stop number							

## Long drill (25 mm)

Implant diameter/drill type		Implant length					
		L 7.0	L 9.0	L 11.0	L 13.0	L 15.0	
QUATTROCONE							
	All implant diameters Pilot drill Ø2.0mm		14 (4-14-24)	13 (4-14-23)	11 (4-14-21)	9 (4-14-19)	7 (4-14-17)
	D 3.5 Standard/Cortical		28 (4-14-38)	27 (4-14-37)	25 (4-14-35)	23 (4-14-33)	21 (4-14-31)
	D 3.8 Standard/Cortical		66 (4-14-84)	65 (4-14-83)	64 (4-14-82)	62 (4-14-80)	60 (4-14-78)
	D 4.3 Standard/Cortical		42 (4-14-52)	41 (4-14-51)	39 (4-14-49)	37 (4-14-47)	35 (4-14-45)
	D 5.0 Standard/Cortical		56 (4-14-70)	55 (4-14-69)	53 (4-14-67)	51 (4-14-65)	49 (4-14-63)
QUATTROCONE30							
	All implant diameters Pilot drill Ø2.0mm		12 (4-14-22)	10 (4-14-20)	8 (4-14-18)	6 (4-14-16)	
	D 4.3 Standard/Cortical		40 (4-14-50)	38 (4-14-48)	36 (4-14-46)	34 (4-14-44)	
	D 5.0 Standard/Cortical		54 (4-14-68)	52 (4-14-66)	50 (4-14-64)	48 (4-14-62)	
Drill stop number							

## Drill stop Pilot drill

- Stainless steel
- Pilot drill D 2.0



<b>Diameter</b>	2.0 mm	2.0 mm	2.0 mm	2.0 mm	2.0 mm
<b>Length</b>	L 4	L 5	L 6	L 7	L 8
<b>Depth stop No.</b>	1	2	3	4	5
<b>Colour code</b>	grey	grey	grey	grey	grey
<b>Article No.</b>	4-14-11	4-14-12	4-14-13	4-14-14	4-14-15

## Drill stop Pilot drill

- Stainless steel
- Pilot drill D 2.0



<b>Diameter</b>	2.0 mm	2.0 mm	2.0 mm	2.0 mm	2.0 mm
<b>Length</b>	L 9	L 10	L 11	L 12	L 13
<b>Depth stop No.</b>	6	7	8	9	10
<b>Colour code</b>	grey	grey	grey	grey	grey
<b>Article No.</b>	4-14-16	4-14-17	4-14-18	4-14-19	4-14-20

## Drill stop Pilot drill

- Stainless steel
- Pilot drill D 2.0



<b>Diameter</b>	2.0 mm	2.0 mm	2.0 mm	2.0 mm
<b>Length</b>	L 14	L 15	L 16	L 18
<b>Depth stop No.</b>	11	12	13	14
<b>Colour code</b>	grey	grey	grey	grey
<b>Article No.</b>	4-14-21	4-14-22	4-14-23	4-14-24

## Drill stop Standard drill / Cortical drill

- Stainless steel
- Standard drill / Cortical drill  
D 3.2/3.3



<b>Diameter</b>	3.2/3.3 mm	3.2/3.3 mm	3.2/3.3 mm	3.2/3.3 mm	3.2/3.3 mm
<b>Length</b>	L 4	L 5	L 6	L 7	L 8
<b>Depth stop No.</b>	15	16	17	18	19
<b>Colour code</b>	pink	pink	pink	pink	pink
<b>Article No.</b>	4-14-25	4-14-26	4-14-27	4-14-28	4-14-29

## Drill stop Standard drill / Cortical drill

- Stainless steel
- Standard drill / Cortical drill
- D 3.2/3.3



<b>Diameter</b>	3.2/3.3 mm	3.2/3.3 mm	3.2/3.3 mm	3.2/3.3 mm	3.2/3.3 mm
<b>Length</b>	L 9	L 10	L 11	L 12	L 13
<b>Depth stop No.</b>	20	21	22	23	24
<b>Colour code</b>	pink	pink	pink	pink	pink
<b>Article No.</b>	<b>4-14-30</b>	<b>4-14-31</b>	<b>4-14-32</b>	<b>4-14-33</b>	<b>4-14-34</b>

## Drill stop Standard drill / Cortical drill

- Stainless steel
- Standard drill / Cortical drill
- D 3.2/3.3



<b>Diameter</b>	3.2/3.3 mm	3.2/3.3 mm	3.2/3.3 mm	3.2/3.3 mm
<b>Length</b>	L 14	L 15	L 16	L 18
<b>Depth stop No.</b>	25	26	27	28
<b>Colour code</b>	pink	pink	pink	pink
<b>Article No.</b>	<b>4-14-35</b>	<b>4-14-36</b>	<b>4-14-37</b>	<b>4-14-38</b>

## Drill stop Standard drill / Cortical drill

- Stainless steel
- Standard drill / Cortical drill
- D 3.5/3.6



<b>Diameter</b>	3.5/3.6 mm	3.5/3.6 mm	3.5/3.6 mm	3.5/3.6 mm	3.5/3.6 mm
<b>Length</b>	L 5	L 7	L 9	L 10	L 11
<b>Depth stop No.</b>	57	58	59	60	61
<b>Colour code</b>	light blue	light blue	light blue	light blue	light blue
<b>Article No.</b>	<b>4-14-75</b>	<b>4-14-76</b>	<b>4-14-77</b>	<b>4-14-78</b>	<b>4-14-79</b>

## Drill stop Standard drill / Cortical drill

- Stainless steel
- Standard drill / Cortical drill
- D 3.5/3.6



<b>Diameter</b>	3.5/3.6 mm	3.5/3.6 mm	3.5/3.6 mm	3.5/3.6 mm	3.5/3.6 mm
<b>Length</b>	L 12	L 13	L 14	L 16	L 18
<b>Depth stop No.</b>	62	63	64	65	66
<b>Colour code</b>	light blue	light blue	light blue	light blue	light blue
<b>Article No.</b>	<b>4-14-80</b>	<b>4-14-81</b>	<b>4-14-82</b>	<b>4-14-83</b>	<b>4-14-84</b>

## Drill stop Standard drill / Cortical drill

- Stainless steel
- Standard drill / Cortical drill
- D 4.0/4.1



<b>Diameter</b>	4.0/4.1 mm	4.0/4.1 mm	4.0/4.1 mm	4.0/4.1 mm	4.0/4.1 mm
<b>Length</b>	L 4	L 5	L 6	L 7	L 8
<b>Depth stop No.</b>	29	30	31	32	33
<b>Colour code</b>	purple	purple	purple	purple	purple
<b>Article No.</b>	<b>4-14-39</b>	<b>4-14-40</b>	<b>4-14-41</b>	<b>4-14-42</b>	<b>4-14-43</b>

## Drill stop Standard drill / Cortical drill

- Stainless steel
- Standard drill / Cortical drill
- D 4.0/4.1



<b>Diameter</b>	4.0/4.1 mm	4.0/4.1 mm	4.0/4.1 mm	4.0/4.1 mm	4.0/4.1 mm
<b>Length</b>	L 9	L 10	L 11	L 12	L 13
<b>Depth stop No.</b>	34	35	36	37	38
<b>Colour code</b>	purple	purple	purple	purple	purple
<b>Article No.</b>	<b>4-14-44</b>	<b>4-14-45</b>	<b>4-14-46</b>	<b>4-14-47</b>	<b>4-14-48</b>

## Drill stop Standard drill / Cortical drill

- Stainless steel
- Standard drill / Cortical drill
- D 4.0/4.1



<b>Diameter</b>	4.0/4.1 mm	4.0/4.1 mm	4.0/4.1 mm	4.0/4.1 mm
<b>Length</b>	L 14	L 15	L 16	L 18
<b>Depth stop No.</b>	39	40	41	42
<b>Colour code</b>	purple	purple	purple	purple
<b>Article No.</b>	<b>4-14-49</b>	<b>4-14-50</b>	<b>4-14-51</b>	<b>4-14-52</b>

## Drill stop Standard drill / Cortical drill

- Stainless steel
- Standard drill / Cortical drill
- D 4.7/4.8



<b>Diameter</b>	4.7/4.8 mm	4.7/4.8 mm	4.7/4.8 mm	4.7/4.8 mm	4.7/4.8 mm
<b>Length</b>	L 4	L 5	L 6	L 7	L 8
<b>Depth stop No.</b>	43	44	45	46	47
<b>Colour code</b>	brown	brown	brown	brown	brown
<b>Article No.</b>	<b>4-14-57</b>	<b>4-14-58</b>	<b>4-14-59</b>	<b>4-14-60</b>	<b>4-14-61</b>



## Drill stop Standard drill / Cortical drill

- Stainless steel
- Standard drill / Cortical drill
- D 4.7/4.8



<b>Diameter</b>	4.7/4.8 mm	4.7/4.8 mm	4.7/4.8 mm	4.7/4.8 mm	4.7/4.8 mm
<b>Length</b>	L 9	L 10	L 11	L 12	L 13
<b>Depth stop No.</b>	48	49	50	51	52
<b>Colour code</b>	brown	brown	brown	brown	brown
<b>Article No.</b>	<b>4-14-62</b>	<b>4-14-63</b>	<b>4-14-64</b>	<b>4-14-65</b>	<b>4-14-66</b>

## Drill stop Standard drill / Cortical drill

- Stainless steel
- Standard drill / Cortical drill
- D 4.7/4.8



<b>Diameter</b>	4.7/4.8 mm	4.7/4.8 mm	4.7/4.8 mm	4.7/4.8 mm
<b>Length</b>	L 14	L 15	L 16	L 18
<b>Depth stop No.</b>	53	54	55	56
<b>Colour code</b>	brown	brown	brown	brown
<b>Article No.</b>	<b>4-14-67</b>	<b>4-14-68</b>	<b>4-14-69</b>	<b>4-14-70</b>

## Tray Drill stop QUATTROCONE

- sterilisable



<b>Version</b>	extra-short	short	long
<b>Article No.</b>	<b>0-13-122</b>	<b>0-13-123</b>	<b>0-13-124</b>

## Placement instrument Implant

- Manual and ratchet
- Hardened stainless steel



<b>Implant connection</b>	AI	AI	AI
<b>Type</b>	QUATTROCONE30	QUATTROCONE30	QUATTROCONE30
<b>Version</b>	extra-short	short	long
<b>Article No.</b>	<b>4-13-11</b>	<b>4-13-12</b>	<b>4-13-13</b>

## Placement instrument Implant

- Manual and ratchet
- Hardened stainless steel



<b>Implant connection</b>	RI	RI	RI
<b>Type</b>	MICROCONE / QUATTROCONE	MICROCONE / QUATTROCONE	MICROCONE / QUATTROCONE
<b>Version</b>	extra-short	short	long
<b>Article No.</b>	<b>2-13-35</b>	<b>2-13-36</b>	<b>2-13-37</b>

# Surgery

## Placement instrument Implant

- Contra-angle
- Hardened stainless steel



Implant connection	AI	AI	AI
Type	QUATTROCONE30	QUATTROCONE30	QUATTROCONE30
Version	extra-short	short	long
Article No.	4-13-08	4-13-09	4-13-10

## Placement instrument Implant

- Contra-angle
- Hardened stainless steel



Implant connection	RI	RI	RI
Type	MICROCONE / QUATTROCONE	MICROCONE / QUATTROCONE	MICROCONE / QUATTROCONE
Version	extra-short	short	long
Article No.	2-13-32	2-13-33	2-13-34

## Extension ISO shank

- Contra-angle
- Stainless steel



Article No.	0-13-55
-------------	---------

## Paralleling aid

- Titanium Grade 5 CF



Type	long
Diameter (mm)	2.0/3.2
Version	with depth marking
Article No.	0-13-74

## Paralleling aid Implant

- Titanium Grade 5 CF



Implant connection	RI
Version	with depth marking
Article No.	2-13-31

## Torque ratchet

- with infinitely variable torque setting
- 10-40 Ncm
- Hardened stainless steel



Article No.

0-13-28

## Torque ratchet surgical

- with service instrument
- Hardened stainless steel



Article No.

6-13-05

## Ratchet surgical

- Hardened stainless steel



Article No.

6-13-01

## Torque control device

- Hardened stainless steel



Article No.

6-13-02

## Service instrument

- Hardened stainless steel



Article No.

6-13-03

## ISO shank adapter

- Ratchet 0-13-28
- Hardened stainless steel



Article No.

0-13-50

## Drill aid QUATTROCONO 30

• Titanium Grade 5 CF



Article No.

4-13-07

## Depth gauge drill hole

• Titanium Grade 5 CF



Article No.

0-13-75

## Depth gauge gingival height

• Titanium Grade 5 CF



Implant connection

RI

Article No.

0-13-17

# Surgery

Surgical tray QUATTROCONE / QUATTROCONE30	<b>NEW</b>		
			
Version	without contents		
Article No.	<b>0-13-115</b>		

Surgical tray QUATTROCONE / QUATTROCONE30	<b>NEW</b>	<b>NEW</b>	<b>NEW</b>
			
Version	extra-short drills	short drills	long drills
Article No.	<b>0-13-116</b>	<b>0-13-117</b>	<b>0-13-118</b>

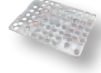
Surgery washing tray QUATTROCONE / QUATTROCONE30	<b>NEW</b>		<b>NEW</b>
			
Version	without contents		Insert
Article No.	<b>0-13-80</b>		<b>0-13-86</b>

Surgery washing tray QUATTROCONE / QUATTROCONE30	<b>NEW</b>	<b>NEW</b>	<b>NEW</b>
			
Version	extra-short drills	short drills	long drills
Article No.	<b>0-13-105</b>	<b>0-13-103</b>	<b>0-13-104</b>



## 0-13-116 Surgical tray / extra short drill



Number	Description	Quantity
0-13-115	Surgical tray without contents	1 pc.
6-13-05	Torque ratchet surgical with service instrument	1 pc.
0-13-04	Placement instrument Hex 1.26 Contra-angle short	1 pc.
0-13-05	Placement instrument Hex 1.26 Contra-angle long	1 pc.
0-13-23	Placement instrument Hex 1.26 Manual and ratchet long	1 pc.
0-13-22	Placement instrument Hex 1.26 Manual and ratchet short	1 pc.
0-13-55	Extension ISO shank Contra-angle	1 pc.
0-13-74	Paralleling aid QUATTROCONE with depth marking	1 pc.
0-13-75	Depth gauge drill hole QUATTROCONE	1 pc.
0-14-77	Needle drill	1 pc.
2-13-31	Paralleling aid Implant with depth marking	1 pc.
2-13-32	Placement instrument Implant Contra-angle extra-short	1 pc.
2-13-33	Placement instrument Implant Contra-angle short	1 pc.
2-13-35	Placement instrument Implant Manual and ratchet extra-short	1 pc.
2-13-36	Placement instrument Implant Manual and ratchet short	1 pc.
4-13-07	Drill aid QUATTROCONE 30	1 pc.
4-13-09	Placement instrument Implant Contra-angle short	1 pc.
4-13-12	Placement instrument Implant Manual and ratchet short	1 pc.
4-14-85	Pilot drill D 2.0 extra-short	1 pc.
4-14-86	Standard drill D 2.0/3.2 extra-short	1 pc.
4-14-87	Cortical drill D 2.3/3.2/3.3 extra-short	1 pc.
4-14-88	Standard drill D 2.0/3.2/4.0 extra-short	1 pc.
4-14-89	Cortical drill D 2.5/4.0/4.1 extra-short	1 pc.
4-14-90	Standard drill D 2.9/4.0/4.7 extra-short	1 pc.
4-14-91	Cortical drill D 3.6/4.7/4.8 extra-short	1 pc.
4-14-92	Standard drill D 2.0/3.5 extra-short	1 pc.
4-14-93	Cortical drill D 2.3/3.5/3.6 extra-short	1 pc.

## 0-13-117 Surgical tray / short drill



Number	Description	Quantity
0-13-115	Surgical tray without contents	1 pc.
6-13-05	Torque ratchet surgical with service instrument	1 pc.
0-13-04	Placement instrument Hex 1.26 Contra-angle short	1 pc.
0-13-05	Placement instrument Hex 1.26 Contra-angle long	1 pc.
0-13-23	Placement instrument Hex 1.26 Manual and ratchet long	1 pc.
0-13-22	Placement instrument Hex 1.26 Manual and ratchet short	1 pc.
0-13-55	Extension ISO shank Contra-angle	1 pc.
0-13-74	Paralleling aid QUATTROCONE with depth marking	1 pc.
0-13-75	Depth gauge drill hole QUATTROCONE	1 pc.
0-14-77	Needle drill	1 pc.
2-13-31	Paralleling aid Implant with depth marking	1 pc.
2-13-32	Placement instrument Implant Contra-angle extra-short	1 pc.
2-13-33	Placement instrument Implant Contra-angle short	1 pc.
2-13-35	Placement instrument Implant Manual and ratchet extra-short	1 pc.
2-13-36	Placement instrument Implant Manual and ratchet short	1 pc.
4-13-07	Drill aid QUATTROCONE 30	1 pc.
4-13-09	Placement instrument Implant Contra-angle short	1 pc.
4-13-12	Placement instrument Implant Manual and ratchet short	1 pc.
4-14-01	Pilot drill D 2.0 short	1 pc.
4-14-02	Standard drill D 2.0/3.2 short	1 pc.
4-14-03	Cortical drill D 2.3/3.2/3.3 short	1 pc.
4-14-04	Standard drill D 2.0/3.2/4.0 short	1 pc.
4-14-05	Cortical drill D 2.5/4.0/4.1 short	1 pc.
4-14-53	Standard drill D 2.9/4.0/4.7 short	1 pc.
4-14-54	Cortical drill D 3.6/4.7/4.8 short	1 pc.
4-14-71	Standard drill D 2.0/3.5 short	1 pc.
4-14-72	Cortical drill D 2.3/3.5/3.6 short	1 pc.

## 0-13-118 Surgical tray / long drill



Number	Description	Quantity
0-13-115	Surgical tray without contents	1 pc.
6-13-05	Torque ratchet surgical with service instrument	1 pc.
0-13-04	Placement instrument Hex 1.26 Contra-angle short	1 pc.
0-13-05	Placement instrument Hex 1.26 Contra-angle long	1 pc.
0-13-23	Placement instrument Hex 1.26 Manual and ratchet long	1 pc.
0-13-22	Placement instrument Hex 1.26 Manual and ratchet short	1 pc.
0-13-55	Extension ISO shank Contra-angle	1 pc.
0-13-74	Paralleling aid QUATTROCONE with depth marking	1 pc.
0-13-75	Depth gauge drill hole QUATTROCONE	1 pc.
0-14-77	Needle drill	1 pc.
2-13-31	Paralleling aid Implant with depth marking	1 pc.
2-13-32	Placement instrument Implant Contra-angle extra-short	1 pc.
2-13-33	Placement instrument Implant Contra-angle short	1 pc.
2-13-35	Placement instrument Implant Manual and ratchet extra-short	1 pc.
2-13-36	Placement instrument Implant Manual and ratchet short	1 pc.
4-13-07	Drill aid QUATTROCONE 30	1 pc.
4-13-09	Placement instrument Implant Contra-angle short	1 pc.
4-13-12	Placement instrument Implant Manual and ratchet short	1 pc.
4-14-06	Pilot drill D 2.0 long	1 pc.
4-14-07	Standard drill D 2.0/3.2 long	1 pc.
4-14-08	Cortical drill D 2.3/3.2/3.3 long	1 pc.
4-14-09	Standard drill D 2.0/3.2/4.0 long	1 pc.
4-14-10	Cortical drill D 2.5/4.0/4.1 long	1 pc.
4-14-55	Standard drill D 2.9/4.0/4.7 long	1 pc.
4-14-56	Cortical drill D 3.6/4.7/4.8 long	1 pc.
4-14-73	Standard drill D 2.0/3.5 long	1 pc.
4-14-74	Cortical drill D 2.3/3.5/3.6 long	1 pc.

## 0-13-105 Surgical washing tray / extra short drill



Number	Description				Quantity
0-13-80	Surgery washing tray without contents				1 pc.
6-13-05	Torque ratchet surgical with service instrument				1 pc.
2-13-33	Placement instrument	Implant	Contra-angle	short	1 pc.
2-13-36	Placement instrument	Implant	Manual and ratchet	short	1 pc.
2-13-32	Placement instrument	Implant	Contra-angle	extra-short	1 pc.
2-13-35	Placement instrument	Implant	Manual and ratchet	extra-short	1 pc.
4-13-09	Placement instrument	Implant	Contra-angle	short	1 pc.
4-13-12	Placement instrument	Implant	Manual and ratchet	short	1 pc.
0-13-04	Placement instrument	Hex 1.26	Contra-angle	short	1 pc.
0-13-22	Placement instrument	Hex 1.26	Manual and ratchet	short	1 pc.
0-13-05	Placement instrument	Hex 1.26	Contra-angle	long	1 pc.
0-13-23	Placement instrument	Hex 1.26	Manual and ratchet	long	1 pc.
0-13-55	Extension ISO shank		Contra-angle		1 pc.
0-13-75	Depth gauge drill hole	QUATTROCONE			1 pc.
2-13-31	Paralleling aid	Implant	with depth marking		1 pc.
0-13-74	Paralleling aid	QUATTROCONE	with depth marking		1 pc.
4-13-07	Drill aid	QUATTROCONE 30			1 pc.
0-14-77	Needle drill				1 pc.
4-14-85	Pilot drill	D 2.0	extra-short		1 pc.
4-14-86	Standard drill	D 2.0/3.2	extra-short		1 pc.
4-14-87	Cortical drill	D 2.3/3.2/3.3	extra-short		1 pc.
4-14-88	Standard drill	D 2.0/3.2/4.0	extra-short		1 pc.
4-14-89	Cortical drill	D 2.5/4.0/4.1	extra-short		1 pc.
4-14-90	Standard drill	D 2.9/4.0/4.7	extra-short		1 pc.
4-14-91	Cortical drill	D 3.6/4.7/4.8	extra-short		1 pc.
4-14-92	Standard drill	D 2.0/3.5	extra-short		1 pc.
4-14-93	Cortical drill	D 2.3/3.5/3.6	extra-short		1 pc.

## 0-13-103 Surgical washing tray / short drill



Number	Description	Quantity
0-13-80	Surgery washing tray without contents	1 pc.
6-13-05	Torque ratchet surgical with service instrument	1 pc.
0-13-04	Placement instrument Hex 1.26 Contra-angle short	1 pc.
0-13-05	Placement instrument Hex 1.26 Contra-angle long	1 pc.
0-13-22	Placement instrument Hex 1.26 Manual and ratchet short	1 pc.
0-13-23	Placement instrument Hex 1.26 Manual and ratchet long	1 pc.
2-13-33	Placement instrument Implant Contra-angle short	1 pc.
2-13-36	Placement instrument Implant Manual and ratchet short	1 pc.
2-13-32	Placement instrument Implant Contra-angle extra-short	1 pc.
2-13-35	Placement instrument Implant Manual and ratchet extra-short	1 pc.
4-13-09	Placement instrument Implant Contra-angle short	1 pc.
4-13-12	Placement instrument Implant Manual and ratchet short	1 pc.
0-13-55	Extension ISO shank Contra-angle	1 pc.
0-13-75	Depth gauge drill hole QUATTROCONE	1 pc.
2-13-31	Paralleling aid Implant with depth marking	1 pc.
0-13-74	Paralleling aid D 2.0/3.2 with depth marking	1 pc.
0-14-77	Needle drill	1 pc.
4-14-01	Pilot drill D 2.0 short	1 pc.
4-14-02	Standard drill D 2.0/3.2 short	1 pc.
4-14-03	Cortical drill D 2.3/3.2/3.3 short	1 pc.
4-14-04	Standard drill D 2.0/3.2/4.0 short	1 pc.
4-14-05	Cortical drill D 2.5/4.0/4.1 short	1 pc.
4-14-53	Standard drill D 2.9/4.0/4.7 short	1 pc.
4-14-54	Cortical drill D 3.6/4.7/4.8 short	1 pc.
4-14-71	Standard drill D 2.0/3.5 short	1 pc.
4-14-72	Cortical drill D 2.3/3.5/3.6 short	1 pc.
4-13-07	Drill aid QUATTROCONE 30	1 pc.



## 0-13-104 Surgical washing tray / long drill



Number	Description			Quantity
0-13-80	Surgery washing tray without contents			1 pc.
6-13-05	Torque ratchet surgical with service instrument			1 pc.
0-13-04	Placement instrument	Hex 1.26	Contra-angle short	1 pc.
0-13-05	Placement instrument	Hex 1.26	Contra-angle long	1 pc.
0-13-23	Placement instrument	Hex 1.26	Manual and ratchet long	1 pc.
0-13-22	Placement instrument	Hex 1.26	Manual and ratchet short	1 pc.
2-13-33	Placement instrument	Implant	Contra-angle short	1 pc.
2-13-36	Placement instrument	Implant	Manual and ratchet short	1 pc.
2-13-32	Placement instrument	Implant	Contra-angle extra-short	1 pc.
2-13-35	Placement instrument	Implant	Manual and ratchet extra-short	1 pc.
4-13-09	Placement instrument	Implant	Contra-angle short	1 pc.
4-13-12	Placement instrument	Implant	Manual and ratchet short	1 pc.
0-13-55	Extension ISO shank Contra-angle			1 pc.
0-13-75	Depth gauge drill hole QUATTROCONE			1 pc.
2-13-31	Paralleling aid	Implant	with depth marking	1 pc.
0-13-74	Paralleling aid	QUATTROCONE	with depth marking	1 pc.
0-14-77	Needle drill			1 pc.
4-14-06	Pilot drill	D 2.0	long	1 pc.
4-14-07	Standard drill long			1 pc.
4-14-08	Cortical drill long			1 pc.
4-14-09	Standard drill long			1 pc.
4-14-10	Cortical drill long			1 pc.
4-14-55	Standard drill long			1 pc.
4-14-56	Cortical drill long			1 pc.
4-14-73	Standard drill long			1 pc.
4-14-74	Cortical drill long			1 pc.
4-13-07	Drill aid QUATTROCONE 30			1 pc.

## Implant pick-up Open tray

- incl. retention screw
- Titanium Grade 5 CF



Implant connection	AI	RI	RI
Version	short	short	long
Article No.	4-04-01	2-04-01	2-04-02

## Implant pick-up Closed tray

- incl. abutment screw
- incl. Positioning cap
- Titanium Grade 5 CF



Implant connection	RI
Article No.	2-04-17

## Custom implant pick-up Open tray

- incl. retention screw
- Titanium Grade 5 CF



Implant connection	RI	RI
Version	short	long
Article No.	2-04-07	2-04-08

## Custom implant pick-up Closed tray

- incl. abutment screw
- incl. Positioning cap
- Titanium Grade 5 CF



Implant connection	RI
Article No.	2-04-18

## Emergence profile for implant pick-up customised

- Peek



Diameter	4.5 mm	4.5 mm	5.5 mm	5.5 mm	6.5 mm	6.5 mm
Gingiva height	1-2 mm	3-6 mm	1-2 mm	3-6 mm	1-2 mm	3-6 mm
Article No.	2-04-09	2-04-12	2-04-10	2-04-13	2-04-11	2-04-14

## Implant pick-up retention screw Open tray

• Titanium Grade 5 CF



Implant connection	RI	RI
Type	short	long
Article No.	<b>2-04-04</b>	<b>2-04-05</b>

## Positioning caps for implant pick-up Closed tray

• POM



Implant connection	RI
Article No.	<b>2-04-19</b>

## Laboratory implant

• Titanium Grade 5 CF



Implant connection	AI	AI	RI	RI
Type		CADCAM		CADCAM
Placement instrument		4-05-03		2-05-03
Article No.	<b>4-05-01</b>	<b>4-05-02</b>	<b>2-05-01</b>	<b>2-05-02</b>

## Placement instrument laboratory implant CAD/CAM

• Stainless steel



Implant connection	AI	RI
Article No.	<b>4-05-03</b>	<b>2-05-03</b>

## Abutment screw

• Titanium Grade 5 CF



Placement instrument	Hex 1.26	Hex 1.26	Ball Torx	Ball Torx	Ball Torx
Article No.	<b>2-06-02</b>	<b>2-06-03</b>	<b>2-06-05</b>	<b>2-06-07</b>	<b>2-06-08</b>

Please note: The correct choice of the abutment screw is stated with the respective abutment in the catalogue.

## Abutment screw

- Titanium Grade 5 CF



Placement instrument	Hex 1.26
Article No.	4-06-01
Please note:	The correct choice of the abutment screw is stated with the respective abutment in the catalogue.

## Laboratory screw

- red coated



Article No.	2-06-04	4-06-02
Please note:	The correct choice of the laboratory screw is stated with the respective abutment in the catalogue.	

## Temporary abutment straight

- Titan/PVDF
- incl. abutment screw
- Recommended torque: 25 Ncm



Implant connection	RI
Gingiva height	3.5 mm
Diameter	5.5 mm
Abutment screw	2-06-03
Laboratory screw	2-06-04
Article No.	2-17-08

## Temporary abutment angled

- Titan/PVDF
- incl. abutment screw
- Type 1 = angled over flat
- Type 2 = angled over corner
- Recommended torque: 25 Ncm



Implant connection	RI
Gingiva height	3.5 mm
Diameter	5.5 mm
Abutment screw	2-06-03
Laboratory screw	2-06-04
Article No. Type 1	2-17-09
Article No. Type 2	2-17-10

## Temporary abutment straight

- Titanium Grade 5 CF
- incl. abutment screw
- Recommended torque: 25 Ncm



Implant connection	RI
Placement instrument	Hex 1.26
Abutment screw	2-06-03
Laboratory screw	2-06-04
Article No.	<b>2-17-07</b>

## Standard abutment straight

- Titanium Grade 5 CF
- incl. abutment screw
- Recommended torque: 25 Ncm



Implant connection	RI
Gingiva height	0 mm
Diameter	3.5 mm
Placement instrument	Hex 1.26
Abutment screw	2-06-03
Laboratory screw	2-06-04
Article No.	<b>2-07-20</b>

## Standard abutment straight

- Titanium Grade 5 CF
- incl. abutment screw
- Recommended torque: 25 Ncm



Implant connection	RI	RI	RI
Gingiva height	1.5 mm	1.5 mm	1.5 mm
Diameter	4.5 mm	5.5 mm	6.5 mm
Placement instrument	Hex 1.26	Hex 1.26	Hex 1.26
Abutment screw	2-06-03	2-06-03	2-06-03
Laboratory screw	2-06-04	2-06-04	2-06-04
Article No.	<b>2-07-01</b>	<b>2-07-02</b>	<b>2-07-03</b>

## Standard abutment straight

- Titanium Grade 5 CF
- incl. abutment screw
- Recommended torque: 25 Ncm



Implant connection	RI	RI	RI
Gingiva height	3.0 mm	3.0 mm	3.0 mm
Diameter	4.5 mm	5.5 mm	6.5 mm
Placement instrument	Hex 1.26	Hex 1.26	Hex 1.26
Abutment screw	2-06-03	2-06-03	2-06-03
Laboratory screw	2-06-04	2-06-04	2-06-04
Article No.	<b>2-07-04</b>	<b>2-07-05</b>	<b>2-07-06</b>



## Standard abutment straight

- Titanium Grade 5 CF
- incl. abutment screw
- Recommended torque: 25 Ncm



Implant connection	RI	RI	RI
Gingiva height	5.0 mm	5.0 mm	5.0 mm
Diameter	4.5 mm	5.5 mm	6.5 mm
Placement instrument	Hex 1.26	Hex 1.26	Hex 1.26
Abutment screw	2-06-03	2-06-03	2-06-03
Laboratory screw	2-06-04	2-06-04	2-06-04
Article No.	<b>2-07-23</b>	<b>2-07-24</b>	<b>2-07-25</b>

## Standard abutment angled 18°

- Titanium Grade 5 CF
- incl. abutment screw
- Type 1 = angled over flat
- Type 2 = angled over corner
- Recommended torque: 25 Ncm



Implant connection	RI	RI	RI
Gingiva height	1.5 mm	1.5 mm	1.5 mm
Diameter	4.5 mm	5.5 mm	6.5 mm
Placement instrument	Hex 1.26	Hex 1.26	Hex 1.26
Abutment screw	2-06-03	2-06-03	2-06-03
Laboratory screw	2-06-04	2-06-04	2-06-04
Article No. Type 1	<b>2-07-07</b>	<b>2-07-08</b>	<b>2-07-09</b>
Article No. Type 2	<b>2-07-13</b>	<b>2-07-14</b>	<b>2-07-15</b>

## Standard abutment angled 18°

- Titanium Grade 5 CF
- incl. abutment screw
- Type 1 = angled over flat
- Type 2 = angled over corner
- Recommended torque: 25 Ncm



Implant connection	RI	RI	RI
Gingiva height	3.0 mm	3.0 mm	3.0 mm
Diameter	4.5 mm	5.5 mm	6.5 mm
Placement instrument	Hex 1.26	Hex 1.26	Hex 1.26
Abutment screw	2-06-03	2-06-03	2-06-03
Laboratory screw	2-06-04	2-06-04	2-06-04
Article No. Type 1	<b>2-07-10</b>	<b>2-07-11</b>	<b>2-07-12</b>
Article No. Type 2	<b>2-07-16</b>	<b>2-07-17</b>	<b>2-07-18</b>

## Standard abutment angled 18°

- Titanium Grade 5 CF
- incl. abutment screw
- Type 1 = angled over flat
- Type 2 = angled over corner
- Recommended torque: 25 Ncm



Implant connection	RI	RI	RI
Gingiva height	5.0 mm	5.0 mm	5.0 mm
Diameter	4.5 mm	5.5 mm	6.5 mm
Placement instrument	Hex 1.26	Hex 1.26	Hex 1.26
Abutment screw	2-06-03	2-06-03	2-06-03
Laboratory screw	2-06-04	2-06-04	2-06-04
Article No. Type 1	<b>2-07-26</b>	<b>2-07-27</b>	<b>2-07-28</b>
Article No. Type 2	<b>2-07-29</b>	<b>2-07-30</b>	<b>2-07-31</b>

## Castable gold abutment

- AU 60%; Pd 20%; Pt 19%; Ir 1%
- Cast-on
- incl. abutment screw
- Recommended torque: 25 Ncm



Implant connection	RI
Gold weight (g)	0,35
Placement instrument	Hex 1.26
Abutment screw	2-06-03
Laboratory screw	2-06-04
Article No.	<b>2-08-01</b>

## Castable gold abutment rotating

- AU 60%; Pd 20%; Pt 19%; Ir 1%
- Cast-on
- incl. abutment screw
- Recommended torque: 25 Ncm



Implant connection	RI
Gold weight (g)	0,28
Placement instrument	Hex 1.26
Abutment screw	2-06-03
Laboratory screw	2-06-04
Article No.	<b>2-08-02</b>

## Castable CoCr abutment

- CrCo alloy / CTE 14.1
- Cast-on
- incl. abutment screw
- Recommended torque: 25 Ncm



Implant connection	RI
Placement instrument	Hex 1.26
Abutment screw	2-06-03
Laboratory screw	2-06-04
Article No.	<b>2-10-02</b>

**Please note:** The Castable CoCr abutment may be cast on with NPM alloys where as the liquidus temperature does not exceed 1420°C.

## Castable CoCr abutment rotating

- CrCo alloy / CTE 14.1
- Cast-on
- incl. abutment screw
- Recommended torque: 25 Ncm



Implant connection	RI
Placement instrument	Hex 1.26
Abutment screw	2-06-03
Laboratory screw	2-06-04
Article No.	<b>2-10-03</b>

**Please note:** The Castable CoCr abutment may be cast on with NPM alloys where as the liquidus temperature does not exceed 1420°C.

## Solid abutment straight

- Titanium Grade 5 CF
- incl. abutment screw
- Recommended torque: 25 Ncm



Implant connection	RI
Gingiva height	3.5 mm
Diameter	5.5 mm
Placement instrument	Hex 1.26
Abutment screw	2-06-03
Laboratory screw	2-06-04
Article No.	2-07-19

Please note: The Solid abutment will be delivered additional with Laboratory screw.

## Solid abutment angled 18°

- Titanium Grade 5 CF
- incl. abutment screw
- Type 1 = angled over flat
- Type 2 = angled over corner
- Recommended torque: 25 Ncm



Implant connection	RI
Gingiva height	3.5 mm
Diameter	5.5 mm
Placement instrument	Hex 1.26
Abutment screw	2-06-03
Laboratory screw	2-06-04
Article No. Type 1	2-07-21
Article No. Type 2	2-07-22

Please note: The Solid abutment will be delivered additional with Laboratory screw.

## Scanbody

- Titanium
- specially coated
- incl. retention screw



Implant connection	AI	RI
retention screw	2-06-06	2-06-06
Article No.	4-09-01	2-09-10

Please note: The Scanbody is sterilisable and for intra-oral scanning.

## Titanium base ASC Flex

- angled screw channel
- Titanium Grade 5 CF
- incl. abutment screw
- Type SF = Screw channel angled over the flat of the scanbody Type
- Type SC = Screw channel angled over the right corner of the scanbody
- Recommended torque: 25 Ncm



Implant connection	RI	RI
Chimney height	3.5-6.5	3.5-6.5
Gingiva height	1.2 mm	2.5 mm
Placement instrument	Ball Torx	Ball Torx
Abutment screw	2-06-07	2-06-08
Article No. Type 1	2-09-19	2-09-21
Article No. Type 2	2-09-20	2-09-22

Please note: To screw in the titanium base ASC Flex you need the Placement instrument Ball-Torx 0-13-60, 0-13-59 or 6-13-06. To select the desired direction of the angled screw channel, please consider the Instruction for use.

## Modelling cap set

- burn-out plastic
- Scope of Delivery: four chimney heights

Modelling cap set straight  
Modelling cap set angled

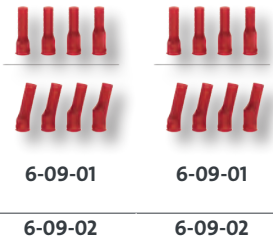

6-09-01 6-09-01  
6-09-02 6-09-02

## Titanium base ASC Flex rotating

- angled screw channel
- Titanium Grade 5 CF
- incl. abutment screw
- Recommended torque: 25 Ncm



Implant connection	RI
Chimney height	3.5-6.5
Gingiva height	1.2 mm
Placement instrument	Ball Torx
Abutment screw	2-06-07
Article No.	2-09-23

**Please note:** To screw in the titanium base ASC Flex you need the Placement instrument Ball-Torx 0-13-60, 0-13-59 or 6-13-06. To select the desired direction of the angled screw channel, please consider the Instruction for use.

## Modelling cap set

- burn-out plastic
- Scope of Delivery: four chimney heights

Modelling cap set straight  
Modelling cap set angled

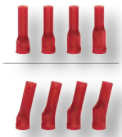

6-09-01  
6-09-02

## Titanium base 2<sup>nd</sup> Generation

- Titanium Grade 5 CF
- incl. abutment screw
- Recommended torque: 25 Ncm



Implant connection	RI	RI	RI	RI
Chimney height	3.5 mm	3.5 mm	5.5 mm	5.5 mm
Gingiva height	0.6 mm	1.1 mm	0.6 mm	1.1 mm
Placement instrument	Hex 1.26	Hex 1.26	Hex 1.26	Hex 1.26
Abutment screw	2-06-03	2-06-03	2-06-03	2-06-03
Laboratory screw	2-06-04	2-06-04	2-06-04	2-06-04
Article No.	2-09-11	2-09-13	2-09-12	2-09-14

## Titanium base Bridges/ bars 2<sup>nd</sup> Generation

- rotating
- Titanium Grade 5 CF
- incl. abutment screw
- Recommended torque: 25 Ncm



Implant connection	RI
Chimney height	3.5 mm
Gingiva height	0.6 mm
Placement instrument	Hex 1.26
Abutment screw	2-06-03
Laboratory screw	2-06-04
Article No.	<b>2-09-15</b>

## Titanium base Cerec®

- Titanium Grade 5 CF
- incl. abutment screw
- Recommended torque: 25 Ncm

NEW

NEW



Implant connection	RI	RI
Chimney height	4.7 mm	4.7 mm
Gingiva height	0.65 mm	2.0 mm
Placement instrument	Hex 1.26	Hex 1.26
Abutment screw	2-06-03	2-06-03
Laboratory screw	2-06-04	2-06-04
Article No.	<b>2-09-17</b>	<b>2-09-24</b>

## ScanPost Cerec®

- Titanium Grade 5 CF
- incl. retention screw



Implant connection	RI
Abutment screw	2-06-03
Article No.	<b>2-09-18</b>

## PreFace abutment Titanium Grade 5 CF

- incl. abutment screw
- Recommended torque: 25 Ncm



Implant connection	AI	AI	RI	RI
Diameter	11.5 mm	16.0 mm	11.5 mm	16.0 mm
Placement instrument	Hex 1.26	Hex 1.26	Hex 1.26	Hex 1.26
Abutment screw	4-06-01	4-06-01	2-06-03	2-06-03
Laboratory screw	4-06-02	4-06-02	2-06-04	2-06-04
Article No.	<b>4-90-02</b>	<b>4-90-03</b>	<b>2-90-02</b>	<b>2-90-03</b>



## PreFace abutment CrCo alloy / CTE 14.1

- incl. abutment screw
- Recommended torque: 25 Ncm



Implant connection	RI
Diameter	16.0 mm
Placement instrument	Hex 1.26
Abutment screw	2-06-03
Laboratory screw	2-06-04
Article No.	<b>2-90-06</b>

## TI-Forms-Abutment for Ceramill

- Titanium Grade 5 CF
- incl. abutment screw
- Recommended torque: 25 Ncm



Implant connection	RI
Diameter	11.5 mm
Placement instrument	Hex 1.26
Abutment screw	2-06-03
Laboratory screw	2-06-04
Article No.	<b>2-90-07-AG</b>

Please note: This is used with AmannGirrbach / Ceramill and Scanbody

## TI-Forms-Abutment for M-Series

- Titanium Grade 5 CF
- incl. abutment screw
- Recommended torque: 25 Ncm



Implant connection	RI
Diameter	11.5 mm
Placement instrument	Hex 1.26
Abutment screw	2-06-03
Laboratory screw	2-06-04
Article No.	<b>2-90-07-ST</b>

Please note: This is used with Straumann/M-series.

## MedentiBASE abutment straight

- Titanium Grade 5 CF
- Recommended torque: 25 Ncm



Implant connection	RI	RI	RI	RI	RI
Gingiva height	0.5 mm	1.5 mm	2.5 mm	3.5 mm	4.5 mm
Placement instrument	0-13-37	0-13-37	0-13-37	0-13-37	0-13-37
Article No.	<b>2-28-01</b>	<b>2-28-02</b>	<b>2-28-03</b>	<b>2-28-04</b>	<b>2-28-05</b>

# Prosthetics

## MedentiBASE bridge screw

NEW

- Titanium Grade 5 CF
- Recommended torque: 15 Ncm



Placement instrument  
Article No.

Hex 1.26  
0-06-03

Ball Torx  
6-28-01

## MedentiBASE prosthetic components

NEW

NEW

- incl. bridge screw
- Recommended torque: 15 Ncm
- titanium base / titanium cap:  
incl. bridge screw
- Material: Titanium grade 5 KV
- Material scanbody: Titanium



Description

titanium base

titanium cap  
Flex

titanium base  
ASC

Placement instrument

Hex 1.26

Hex 1.26

Ball Torx

Abutment screw

0-06-03

0-06-03

6-28-01

Article No.

0-28-05

0-28-22

6-28-02

## MedentiBASE prosthetic components

- incl. bridge screw
- Material plastic coping: Tecanat (PC)
- Material HSL coping: Au 60%; Pd 20%; Pt 19%; Ir 1%



Description

gold cap,  
castable

plastic cap

Article No.

0-28-07

0-28-08

## MedentiBASE Prosthetic components for passive fit

- incl. bridge screw
- Recommended torque: 15 Ncm
- Adhesive base material: Titanium grade 5 CF
- Adhesive sleeve incl. modeling screw



Description

adhesive cap

adhesive  
casing

adhesive cap

adhesive  
casing

Version

Short

Short

Long

Long

Placement instrument

Hex 1.26

Hex 1.26

Abutment screw

0-06-03

0-06-03

Article No.

0-28-14

0-28-16

0-28-15

0-28-17

## MedentiBASE scanbody

- Titanium specially coated
- incl. bridge screw







Article No.

0-28-13

Please note: The Scanbody is sterilisable and for intra-oral scanning.





## MedentiBASE accessories

- Material placement instrument: Stainless steel
- Material cover cap: Titanium grade 5 KV
- Material implant pick-up: Titanium grade 5 KV
- Material laboratory implant: Titanium grade 5 KV
- Material laboratory implant CAD/CAM: Stainless steel

Description					
<b>Placement instrument</b>		Hex 1.26	Hex 1.26		0-13-37
<b>Article No.</b>	<b>0-13-37</b>	<b>0-28-04</b>	<b>0-28-12</b>	<b>0-28-20</b>	<b>0-28-21</b>

## Multi-unit abutment straight



- Titanium Grade 5 CF
- Sterile packaged
- Recommended torque: 25 Ncm

				
<b>Implant connection</b>	RI	RI	RI	RI
<b>Gingiva height</b>	1.5 mm	2.5 mm	3.5 mm	5.5 mm
<b>Placement instrument</b>	0-13-76	0-13-76	0-13-76	0-13-76
<b>Article No.</b>	<b>2-31-01</b>	<b>2-31-16</b>	<b>2-31-02</b>	<b>2-31-03</b>

## Multi-unit abutment angled 17°

- Titanium Grade 5 CF
- Sterile packaged
- incl. abutment screw
- Type 1 = angled over flat
- Type 2 = angled over corner
- Recommended torque: 25 Ncm





			
<b>Implant connection</b>	RI	RI	RI
<b>Gingiva height (mm)</b>	1.1/2.5	2.1/3.5	4.1/5.5
<b>Placement instrument</b>	Hex 1.26	Hex 1.26	Hex 1.26
<b>Abutment screw</b>	2-06-02	2-06-02	2-06-02
<b>Article No. Type 1</b>	<b>2-31-04</b>	<b>2-31-05</b>	<b>2-31-06</b>
<b>Article No. Type 2</b>	<b>2-31-10</b>	<b>2-31-11</b>	<b>2-31-12</b>

## Multi-unit abutment angled 30°

- Titanium Grade 5 CF
- Sterile packaged
- incl. abutment screw
- Type 1 = angled over flat
- Type 2 = angled over corner
- Recommended torque: 25 Ncm



			
<b>Implant connection</b>	RI	RI	RI
<b>Gingiva height (mm)</b>	0.6/3.0	1.6/4.0	3.1/5.5
<b>Placement instrument</b>	Hex 1.26	Hex 1.26	Hex 1.26
<b>Abutment screw</b>	2-06-02	2-06-02	2-06-02
<b>Article No. Type 1</b>	<b>2-31-07</b>	<b>2-31-08</b>	<b>2-31-09</b>
<b>Article No. Type 2</b>	<b>2-31-13</b>	<b>2-31-14</b>	<b>2-31-15</b>

# Prosthetics

## Multi-unit abutment angled 30°

- Titanium Grade 5 CF
- Sterile packaged
- incl. abutment screw
- Recommended torque: 25 Ncm



<b>Implant connection</b>	AI	AI	AI
<b>Gingiva height</b>	1.5 mm	3.0 mm	4.5 mm
<b>Placement instrument</b>	Hex 1.26	Hex 1.26	Hex 1.26
<b>Abutment screw</b>	4-06-01	4-06-01	4-06-01
<b>Article No.</b>	<b>4-31-01</b>	<b>4-31-02</b>	<b>4-31-03</b>

## Multi-unit bridge screw

- Material: Titanium grade 5 KV
- Recommended torque: 15 Ncm

NEW

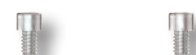

<b>Placement instrument</b>	Hex 1.26	Ball Torx
<b>Article No.</b>	<b>0-31-02</b>	<b>6-31-01</b>

## Multi-unit prosthetic components

- Recommended torque: 15 Ncm
- titanium base / titanium cap: incl. bridge screw
- Material: Titanium grade 5 KV
- modelling sleeve: without Bridge screw
- Material: Tecanat (PC)

NEW

NEW



<b>Description</b>	titanium base	titanium base ASC	titanium cap Flex	modelling sleeve
<b>Placement instrument</b>	Hex 1.26	Ball Torx	Hex 1.26	
<b>Screw</b>	0-31-02	6-31-01	0-31-02	
<b>Article No.</b>	<b>0-31-09</b>	<b>6-31-02</b>	<b>0-31-20</b>	<b>0-31-11</b>

**Please note:** The Multi-unit modelling sleeve can be used with the Multi-unit titanium base and Multi-unit titanium cap.

## Multi-unit prosthetic components

- incl. bridge screw
- Recommended torque: 15 Ncm
- Material gold cap, castable: "(AU 60%; Pd 20%; Pt 19%; Ir 1%)"
- Material CoCr cap: CrCo alloy / CTE 14.1



<b>Description</b>	gold cap, castable	CoCr cap
<b>Placement instrument</b>	Hex 1.26	Hex 1.26
<b>Screw</b>	0-31-02	0-31-02
<b>Article No.</b>	<b>0-31-07</b>	<b>0-31-08</b>

## Multi-unit screw patrix

- Material Novaloc:  
Titanium grade 5 KV ADLC coated
- Material MedentiLOC:  
Titanium grade 5 KV TiN coated
- Recommended torque: 15 Ncm



NEW

NEW

<b>Description</b>		
<b>Placement instrument</b>	Hex 1.26	Hex 1.26
<b>Article No.</b>	<b>0-31-18</b>	<b>0-31-19</b>

## Multi-unit scanbody

- Titanium specially coated
- incl. bridge screw

<b>Version</b>		
<b>Placement instrument</b>	Hex 1.26	Hex 1.26
<b>Screw</b>	0-31-02	0-31-02
<b>Article No.</b>	<b>0-31-01</b>	<b>0-31-16</b>

Please note: The Scanbody is sterilisable and for intra-oral scanning.



## Multi-unit Laboratory implant

- Titanium Grade 5 CF

<b>Version</b>			
<b>Type</b>	straight	angled 17°	angled 30°
<b>Article No.</b>	<b>0-31-05</b>	<b>0-31-12</b>	<b>0-31-13</b>

## Multi-unit Laboratory implant CAD/CAM

- Titanium Grade 5 CF

<b>Version</b>			
<b>Type</b>	straight	angled 17°	angled 30°
<b>Placement instrument</b>	0-13-76	0-13-17	0-13-17
<b>Article No.</b>	<b>0-31-10</b>	<b>0-31-14</b>	<b>0-31-15</b>

## Multi-unit accessories

- 0-13-76 Placement instrument
- Multi-unit abutment
- 0-31-03 Multi-unit cover cap
- 0-31-04 Multi-unit implant pick-up
- 0-31-17 Placement instrument laboratory implant CAD/CAM

<b>Article No.</b>				
	<b>0-13-76</b>	<b>0-31-03</b>	<b>0-31-04</b>	<b>0-31-17</b>

# Prosthetics

## MedentiLOC abutment straight

- Titanium Grade 5 CF
- TiN coated
- Recommended torque: 25 Ncm



Implant connection	RI	RI	RI	RI	RI
Gingiva height	1.5 mm	2.5 mm	3.5 mm	4.5 mm	5.5 mm
Placement instrument	Hex 1,26	Hex 1,26	Hex 1,26	Hex 1,26	Hex 1,26
Article No.	2-21-01	2-21-02	2-21-03	2-21-04	2-21-05

## MedentiLOC abutment angled 15°

- Titanium Grade 5 CF
- TiN coated
- incl. abutment screw
- Type 1 = angled over flat
- Type 2 = angled over corner
- Recommended torque: 25 Ncm



Implant connection	RI	RI	RI	RI	RI
Gingiva height (mm)	1.0/2.0	2.0/3.0	3.0/4.0	4.0/5.0	5.0/6.0
Placement instrument	Ball Hex	Ball Hex	Ball Hex	Ball Hex	Ball Hex
Abutment screw	2-06-02	2-06-02	2-06-02	2-06-02	2-06-02
Article No. Type 1	2-21-06	2-21-07	2-21-08	2-21-09	2-21-10
Article No. Type 2	2-21-11	2-21-12	2-21-13	2-21-14	2-21-15

**Please note:** To screw in the angled MedentiLOC abutments you need the special Placement instrument Ball-Hex 1.26 mm 0-13-39 or 0-13-38.

## Novaloc® Processing package

- Matrix housing, titanium/PEEK
- Retention insert white  
Retention force: light
- Retention insert yellow  
Retention force: medium
- Retention insert green  
Retention force: strong
- Mounting collar, silicone
- 2 pcs per package
- incl. mounting insert



Material matrix housing	Titanium	Peek
Article No.	2010.601	2010.611

**Please note:** The entire product overview is available in section Novaloc.

## Placement instrument MedentiLOC abutment, angled

- Stainless steel
- Ball Hex



Version	Manual and ratchet	Contra-angle
Article No.	0-13-38	0-13-39

## MedentiLOC Laboratory implant

- Stainless steel



Version	straight	angled
Article No.	0-21-01	0-21-02



## Novaloc abutment straight

- Titanium Grade 5 CF
- ADLC coated
- Recommended torque: 25 Ncm



Implant connection	RI	RI	RI	RI	RI
Gingiva height	1.0 mm	2.0 mm	3.0 mm	4.0 mm	5.0 mm
Placement instrument	Hex 1.26	Hex 1.26	Hex 1.26	Hex 1.26	Hex 1.26
Article No.	2-23-01	2-23-02	2-23-03	2-23-04	2-23-05

## Novaloc abutment angled 15°

- Titanium Grade 5 CF
- ADLC coated
- incl. abutment screw
- Type 1 = angled over flat
- Type 2 = angled over corner
- Recommended torque: 25 Ncm



Implant connection	RI	RI	RI	RI	RI
Gingiva height (mm)	1.0/2.0	2.0/3.0	3.0/4.0	4.0/5.0	5.0/6.0
Placement instrument	Ball Torx	Ball Torx	Ball Torx	Ball Torx	Ball Torx
Abutment screw	2-06-05	2-06-05	2-06-05	2-06-05	2-06-05
Article No. Type 1	2-23-06	2-23-07	2-23-08	2-23-09	2-23-10
Article No. Type 2	2-23-11	2-23-12	2-23-13	2-23-14	2-23-15

Please note: To screw in the angled Novaloc abutments you need the special Placement instrument Ball-Torx 0-13-60 or 0-13-59.

## Novaloc® Processing package

- Matrix housing, titanium/PEEK
- Retention insert white  
Retention force: light
- Retention insert yellow  
Retention force: medium
- Retention insert green  
Retention force: strong
- Mounting collar, silicone
- 2 pcs per package
- incl. mounting insert



Material matrix housing	Titanium	Peek
Article No.	2010.601	2010.611

Please note: The entire product overview is available in section Novaloc.

## Placement instrument Ball Torx

- Hardened stainless steel



NEW

Version	Manual and ratchet	Contra-angle	Contra-angle
Type	long	long	L 30 mm
Article No.	0-13-59	0-13-60	6-13-06

## Novaloc Laboratory implant

- Stainless steel



Version	straight	angled
Article No.	0-23-01	0-23-02

Picture	Part no.	Part description	Specifications	Amount per package
	2010.101	Novaloc Equipment Box	Incl. 3 tools Instrument brown 2010.741 Instrument blue 2010.731 Instrument grey 2010.751 (without load)	1 pc
	2010.601	Novaloc Processing package titanium	<ul style="list-style-type: none"> <li>• Titanium matrix housing incl. mounting insert</li> <li>• Retention insert white</li> <li>• Retention insert yellow</li> <li>• Retention insert green</li> <li>• Mounting collar, silicone</li> </ul>	2 pcs
	2010.611	Novaloc Processing package PEEK	<ul style="list-style-type: none"> <li>• PEEK matrix housing incl. mounting insert</li> <li>• Retention insert white</li> <li>• Retention insert yellow</li> <li>• Retention insert green</li> <li>• Mounting collar, silicone</li> </ul>	2 pcs
	2010.701	Novaloc Matrix housing, titanium (incl. mounting insert)	Matrix housing: titanium Mounting insert: POM	4 pcs
	2010.702	Novaloc Matrix housing, PEEK (incl. mounting insert)	Matrix housing: PEEK Mounting insert: POM	4 pcs
	special accessory 2010.703	Novaloc Matrix housing, titanium with attachment option (incl. mounting insert)	Matrix housing: titanium Mounting insert: POM	4 pcs
	special accessory 2010.710	Novaloc Retention insert red	PEEK Retention force: extra-light	4 pcs
	2010.711	Novaloc Retention insert white	PEEK Retention force: light	4 pcs
	2010.712	Novaloc Retention insert yellow	PEEK Retention force: medium	4 pcs
	2010.713	Novaloc Retention insert green	PEEK Retention force: strong	4 pcs
	2010.714	Novaloc Retention insert blue	PEEK Retention force: extra-strong	4 pcs
	special accessory 2010.715	Novaloc Retention insert black	PEEK Retention force: ultra-strong	4 pcs
	2010.721	Novaloc Model analogue	Aluminium	4 pcs
	2010.722	Novaloc Forming / fixing matrix	PEEK	4 pcs
	2010.723	Novaloc Processing spacer, white	POM	4 pcs
	2010.724	Novaloc Mounting collar, silicone	Silicone	10 pcs
	2010.725	Novaloc Mounting insert white	POM	4 pcs
	2010.731	Novaloc Demounting tool for mounting inserts + model analogue reposition aid (blue)	Aluminium, steel	1 pc
	2010.741	Novaloc Mounting and demounting tool for retention inserts (brown)	Aluminium, steel	1 pc
	2010.751	Novaloc Matrix housing extractor (grey)	Aluminium, steel	1 pc

## Optiloc abutment straight

- Titanium Grade 5 CF
- ADLC coated
- Recommended torque: 25 Ncm



<b>Implant connection</b>	RI	RI	RI	RI	RI
<b>Gingiva height</b>	1.0 mm	2.0 mm	3.0 mm	4.0 mm	5.0 mm
<b>Placement instrument</b>	0-13-61 0-13-82	0-13-61 0-13-82	0-13-61 0-13-82	0-13-61 0-13-82	0-13-61 0-13-82
<b>Article No.</b>	<b>2-22-01</b>	<b>2-22-02</b>	<b>2-22-03</b>	<b>2-22-04</b>	<b>2-22-05</b>

## Optiloc® Processing package

- Matrix housing, titanium
- Retention insert white  
Retention force: light
- Retention insert yellow  
Retention force: medium
- Retention insert green  
Retention force: strong
- Mounting collar, silicone
- 2 pcs per package

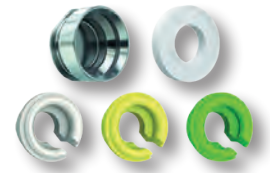

<b>Material matrix housing</b>	Titanium
<b>Article No.</b>	<b>5202.0001</b>
<b>Please note:</b>	The entire product overview is available in section Optiloc.

## Placement instrument Optiloc abutment

- Stainless steel



<b>Version</b>	Manual and ratchet	Contra-angle
<b>Article No.</b>	<b>0-13-61</b>	<b>0-13-82</b>

## Optiloc implant analogue

- Aluminium

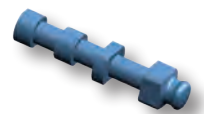

<b>Version</b>	4 piece
<b>Article No.</b>	<b>2102.0024</b>

Picture	Part no.	Part description	Specifications	Amount per package
	5102.0000	Optiloc Equipment Box	Incl. 3 tools Instrument brown 3202.0001 Instrument blue 3202.0002 Instrument grey 3202.0003 (without load)	1 pc
	5202.0001	Optiloc Processing package titanium	<ul style="list-style-type: none"> <li>• Titanium matrix housing</li> <li>• Retention insert white</li> <li>• Retention insert yellow</li> <li>• Retention insert green</li> <li>• Mounting collar, silicone</li> </ul>	2 pcs
	2102.0001	Optiloc Matrix housing, titanium	Matrix housing: titanium	4 pcs
	2102.0009	Optiloc Matrix housing, elliptic	Titanium	4 pcs
	special accessory 2102.0010	Optiloc Matrix housing, titanium with attachment option	Matrix housing: titanium	4 pcs
	special accessory 2102.0003	Optiloc Retention insert red	PEEK Retention force: extra-light	4 pcs
	2102.0004	Optiloc Retention insert white	PEEK Retention force: light	4 pcs
	2102.0005	Optiloc Retention insert yellow	PEEK Retention force: medium	4 pcs
	2102.0006	Optiloc Retention insert green	PEEK Retention force: strong	4 pcs
	2102.0007	Optiloc Retention insert blue	PEEK Retention force: extra-strong	4 pcs
	special accessory 2102.0008	Optiloc Retention insert black	PEEK Retention force: ultra-strong	4 pcs
	2102.0024	Optiloc Model analogue	Aluminium	4 pcs
	2102.0012	Optiloc Forming / fixing matrix	PEEK	4 pcs
	2102.0023	Optiloc Processing spacer	POM	4 pcs
	2102.0011	Optiloc Mounting collar, silicone	Silicone	10 pcs
	3202.0002	Abutment screw driver (lab) + model analog reposition aid (blue)	Aluminium, steel	1 pc
	3202.0001	Optiloc Mounting and demounting tool for retention inserts (brown)	Aluminium, steel	1 pc
	3202.0003	Optiloc Matrix housing extractor (grey)	Aluminium, steel	1 pc

## Planning abutment straight

- Aluminium red coated



Implant connection	RI	RI	RI
Gingiva height	1.5 mm	3.0 mm	5.0 mm
Diameter	4.5 mm	4.5 mm	4.5 mm
Article No.	2-15-01	2-15-02	2-15-03

## Planning abutment angled 18°

- Aluminium red coated
- Type 1 = angled over flat
- Type 2 = angled over corner



Implant connection	RI	RI	RI
Gingiva height	1.5 mm	3.0 mm	5.0 mm
Diameter	4.5 mm	4.5 mm	4.5 mm
Article No. Type 1	2-15-04	2-15-05	2-15-06
Article No. Type 2	2-15-07	2-15-08	2-15-09

## Planning abutment set

- incl. storage box

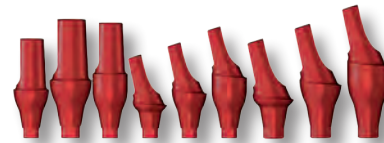

Implant connection	RI
Article No.	2-15-10
Content:	2-15-01, 2-15-02, 2-15-03, 2-15-04, 2-15-05, 2-15-06, 2-15-07, 2-15-08, 2-15-09

# Prosthetic Tools

## Placement instrument Hex 1.26

• Stainless steel



Version	Manual and ratchet	Manual and ratchet	Contra-angle	Contra-angle	Contra-angle
Type	short	long	extra-short	short	long
Article No.	0-13-22	0-13-23	0-13-18	0-13-04	0-13-05

## Placement instrument Ball Torx

• Hardened stainless steel



Version	Manual and ratchet	Contra-angle	Contra-angle
Type			L 30 mm
Article No.	0-13-59	0-13-60	6-13-06
Suitable for:	Novaloc abutment angled, titanium base ASC Flex		

## Placement instrument MedentiLOC abutment, angled

• Stainless steel  
• Ball Hex



Version	Manual and ratchet	Contra-angle
Article No.	0-13-38	0-13-39

## Placement instrument Optiloc abutment

• Stainless steel



Version	Manual and ratchet	Contra-angle
Article No.	0-13-61	0-13-82

## Placement instrument MedentiBASE abutment

• Stainless steel



Version	Manual and ratchet
Article No.	0-13-37



# Prosthetic Tools

## Placement instrument Multi-unit abutment straight

- Stainless steel



Version

Manual and ratchet

Article No.

0-13-76

## Torque ratchet

- with infinitely variable torque setting
- 10-40 Ncm
- Hardened stainless steel



Article No.

0-13-28

## Torque ratchet surgical

- with service instrument
- Hardened stainless steel



Article No.

6-13-05

## Ratchet surgical

- Hardened stainless steel



Article No.

6-13-01

## Torque control device

- Hardened stainless steel



Article No.

6-13-02

## Service instrument

- Hardened stainless steel



Article No.

6-13-03

# Prosthetic Tools

## ISO shank adapter

- Ratchet 0-13-28
- Hardened stainless steel



Article No.

0-13-50

## Altus gingiva gauge



Article No.

2013.901

## Prosthetic tray

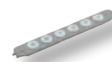

Article No.

0-13-84

[fits article number 0-13-81, extension 6-fold](#)

## Prosthetic tray



Article No.

0-13-81

## Tray Eco

- sterilisable
- incl. silicone pad



Article No.

0-13-51

## Prosthetic tray Eco

- sterilisable
- incl. ratchet 0-13-28
- incl. placement instrument Hex 1.26 0-13-22



Article No.

0-13-52

# Accessories

## MedentiLOC screw patrix Bars

- Titanium Grade 5 CF
- TiN coated
- M 2.0
- Recommended torque: 35 Ncm



Article No.

2000

Please note:

To screw in the MedentiLOC screw patrix you need the Placement instrument hex 2,00 mm M 11-10.

## Novaloc screw patrix Bars

- Titanium Grade 5 CF
- ADLC coated
- M 2.0
- Recommended torque: 35 Ncm



Article No.

6000

Please note:

To screw in the Novaloc screw patrix you need the Placement instrument hex 2,00 mm M 11-10.

## Optiloc screw patrix Bars

- Titanium Grade 5 CF
- ADLC coated
- M 2.0
- Recommended torque: 35 Ncm



Article No.

5000

Please note:

To screw in the straight Optiloc abutments you need the special Placement instrument 0-13-61 / 0-13-82

## X-ray foils QUATTROCONE



Article No.

0-24-15

## Dental implant pass



Article No.

PM06\_02\_0003



**Publisher**

Medentika® GmbH

Date: May 2021

We are certified according to:

**DIN EN ISO 13485**

**Medical Devices Directive 93/42/EEC**

**CE 0483**

The electronic Instructions for Use for our products are available on the website [www.medentika.com/ifu](http://www.medentika.com/ifu)



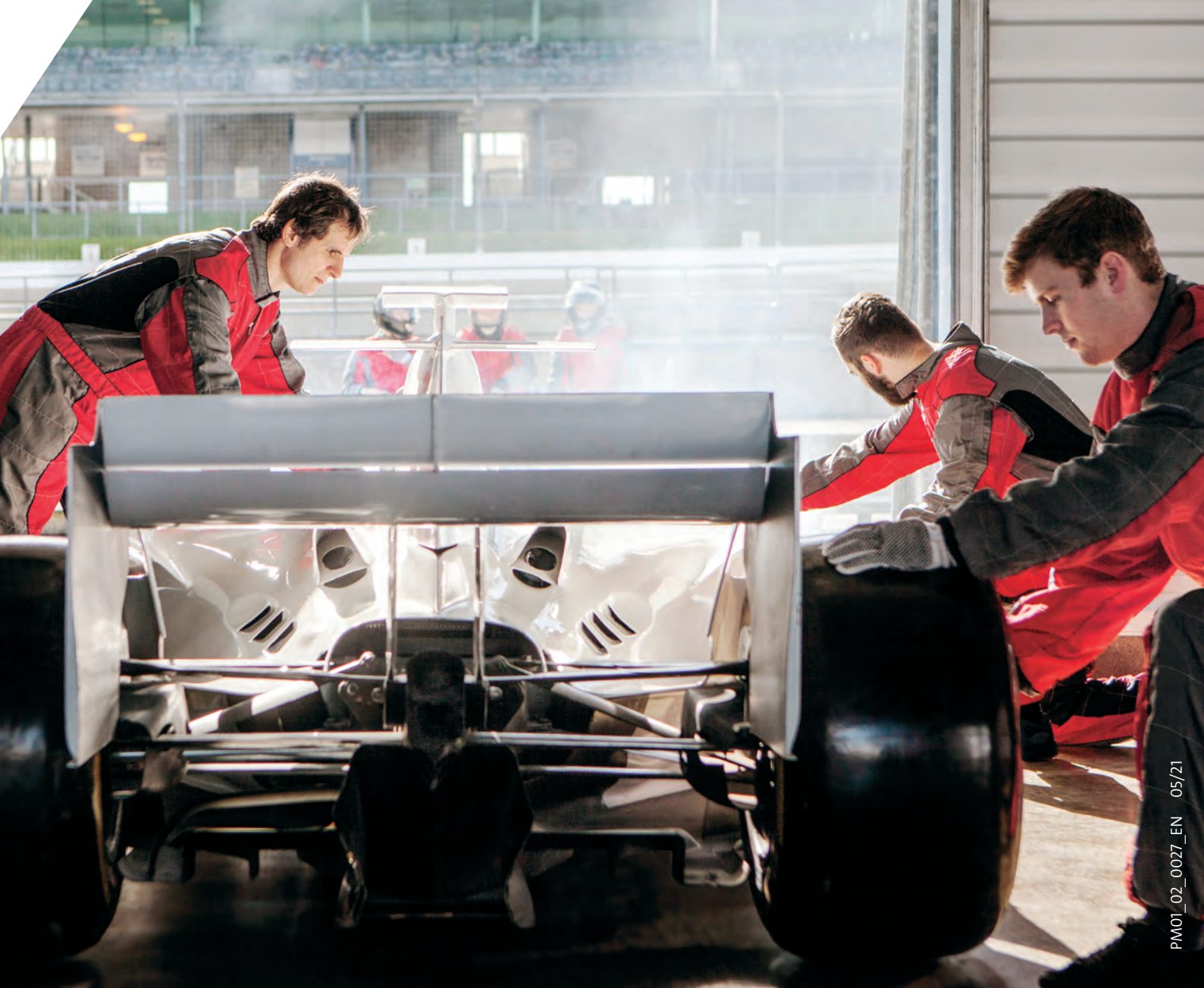

PM01\_02\_0027\_EN 05/21

» Passion for Precision «



Medentika® GmbH  
Hammweg 8–10  
76549 Hügelsheim  
info@medentika.de  
www.medentika.com

© Medentika® GmbH, 2021. All rights reserved.  
Medentika® and/or other trademarks and logos from Medentika® mentioned herein are the trademarks or registered trademarks of Medentika® and/or its affiliates.

 **MEDENTIKA®**  
A Straumann Group Brand